

SPRIET ASSOCIATES
CONSULTING ENGINEERS & ARCHITECTS

To: ✓

PARKER DRAIN 2006 #1629

Township of Strathroy-Caradoc

Sincerely,

Shawn G. Vanacker, C.Tech.

Drainage Superintendent
Norfolk County, Drainage Division
Public Works & Environmental Services Dep
Phone: (519) 582-2100 or (519) 428-0020 – Ext. 602
Fax: (519) 582-4571
Email: shawn.vanacker@norfolkcounty.on.ca
Visit us at: www.norfolkcounty.on.ca



From:
M. A. I.
STEPHENSON



SPRIET ASSOCIATES
ENGINEERS & ARCHITECTS
155 York Street
London, Ontario N6A 1A8
Tel. (519) 672-4100
Fax (519) 433-9351
E-mail MAIL@SPRIET.ON.CA

Our Job No. 205053

June 2, 2006

London, Ontario
June 2, 2006

PARKER DRAIN 2006

Township of Strathroy-Caradoc

To the Mayor and Council
of the Township of Strathroy-Caradoc

Mayor and Council:

We are pleased to present our report on the reconstruction of the Branch "A" and the lower portion of the Main Drain of the Parker Drain serving parts of Lots 9 to 12, Concessions 3 to 5 (former Caradoc) in the Township of Strathroy-Caradoc.

AUTHORIZATION

This report was prepared pursuant to Sections 4 and 78 of the Drainage Act in accordance with instructions received from your Municipality with respect to a motion of Council in accordance with Section 8 of the Drainage Act.

The work on the Main Drain and the existing Branch "A" was initiated by a request signed by some of the affected landowners. The work on the upstream extension of Branch "A" was initiated by a petition signed by a majority of the owners in the area requiring drainage.

DRAINAGE AREA

The total watershed area for the Branch "A" upper closed portion contains approximately 27.2 hectares. The area requiring drainage for the Branch "A" upper closed portion is described as the north half of Lot 11, Concession 4.

HISTORY

The Parker Drain was originally constructed under the provisions of By-Law No. 168 dated July 29, 1889 and last reconstructed pursuant to a report by A.J. DeVos, P. Eng. of Spriet Associates, dated October 17, 1975. The report provided for the closing in of the upper portion of the Main Drain (south of the Canadian Pacific Railway) with 1291 meters of 300mm to 600mm tile, the cleanout of the remaining Main Drain from the C.P.R. to Sutherland Road, and the cleanout of Branch "A".

The lower portion of the Main Drain from Sutherland Road to Olde Drive was cleaned out and reconstructed pursuant to a report by M.P. DeVos, P. Eng. dated November 30, 1998.

EXISTING DRAINAGE CONDITIONS

At a site meeting held with respect to the project and through later discussions, the owners reported the following:

- that the existing Branch "A" has silted in and is not providing a proper drainage outlet
- that the Main Drain has also silted in
- that the portion of Branch "A" south of Century Drive be backfilled and replaced with a new closed drain

At a later date, a petition was submitted to extend Branch "A" upstream into the Novastar Genetics property (Roll No. 40-106).

The Township reviewed the proposed backfilling of Branch "A" with the Department of Fisheries and Oceans (D.F.O.) and the St. Clair Region Conservation Authority. It was deemed that the proposed work was not a Harmful Alteration of Disruption (HADD).

The Ministry of Agriculture, Food and Rural Affairs (OMAFRA) recently reinstated the one third grant on assessments to agricultural lands. However, under this new "Agricultural Drainage Infrastructure Program" the grant will not apply to:

Policy 1.3(f): "The cost of enclosing or replacing an existing open ditch municipal drain with a buried pipe is not eligible for grant if, using normal design standards, more pipe flow capacity is required than can be provided by a single 300mm diameter corrugated plastic pipe (or equivalent capacity). An exception may be made if evidence is provided to the satisfaction of the Director that a drain enclosure is required to address bank slumping or erosion problems on the drain, and the Director's written approval is provided in advance".

We noted that there is slumping of the ditch bank occurring on a length of approximately 250 meters of the portion requested to be backfilled, usually on one side. It is our opinion, that a ditch bottom cleanout of this portion would cause more slumping. The existing channel slopes are steep and portions would require grading to a flatter slope. There may be more areas which may become unstable due to a cleanout and reconstruction to provide tiling depth for the upper watershed area. Therefore, it is our opinion that the best long term solution would be to enclose the channel with a tile and overflow swale.

Accordingly, we contacted OMAFRA with regards to the above upper portion of Branch "A" being backfilled and requested that an exception be made to Policy 1.3(f) due to the possibility of bank slumping and erosion. We provided them with our reasons for requesting the exception and sent photographs of the ditch.

OMAFRA replied to our request for the grant on the backfilling of the upper portion of Branch "A" with a letter dated November 30, 2005. While they agreed that the ditch does exhibit some slumping problems, they were not convinced that drain enclosure is the most effective means of addressing this problem. Therefore they decided not to make an exception to Policy 1.3(f) of the Agricultural Drainage Infrastructure Program and no grant will be provided for the enclosure of this section of the drain.

EXISTING DRAINAGE CONDITIONS (cont'd)

Further, a field investigation and survey of Branch "A" and the Main Drain Open Portions was completed and upon reviewing our findings, we note the following:

- that portions of the open ditches have silted in and do not provide a proper outlet for tributary sub-surface drainage tiles
- that there are trees and brush growing on the banks and bottom along portions of the Branch "A" ditch reducing its capacity during times of high flow and facilitating erosion due to the deflection of water into the banks
- that several locations along the open drains are experiencing erosion due to surface water entering the drain
- that some existing private tiles outletting into the drain require repair and erosion control measures
- that most of the channel through cultivated lands has some grassed buffer, but that some locations have less than the recommended width
- that the upper portion of Branch "A", which is requested to be backfilled, remains dry and only runs water after rain events and snow melt
- this portion of the existing ditch crosses portions of the Brenair Farms Inc. (40-104) and J. Ballantine (40-105) properties which interferes with the efficient and economic operation of the properties

Preliminary design, cost estimates and assessments to clean out the lower portion (Sta.0+775 to Sta. 1+478) and close in the upper portion (Sta.0+274 to Sta.0+775) of Branch "A" were prepared. An informal public meeting was then held to review the findings and preliminary proposals. Further input was provided by the affected owners at that time and the following requests were made:

- that the proposed closed Drain be extended upstream to the Novastar Genetics Inc. property (40-106). A petition was then signed and submitted to the Municipality
- that the Main Drain open ditch be investigated and that the portion between the Branch "A" junction and Sutherland Road be cleaned out as part of this report
- that catchbasins are not required

DESIGN CONSIDERATIONS

The proposed drain was designed, with respect to capacity, using the Drainage Coefficient method contained in the "DRAINAGE GUIDE FOR ONTARIO", Publication 29 by the Ontario Ministry of Agriculture, Food, and Rural Affairs. The Drainage Coefficient defines a depth of water that can be removed in a 24 hour period and is expressed in millimetres per 24 hours. The coefficient used for the closed portion was 24mm per 24 hours.

We would like to point out that there have been indications of sandy soil conditions, but no formal soil investigation has been made.

All of the proposed work has been generally designed and shall be constructed in accordance with the DESIGN AND CONSTRUCTION GUIDELINES FOR WORK UNDER THE DRAINAGE ACT.

RECOMMENDATIONS

We are therefore recommending the following:

OPEN PORTION

- that the existing ditch bottom of the Main Drain and Branch "A" from Sutherland Road to the new tile outlet at Sta.0+775, be cleaned out to provide a proper sub-surface drainage outlet
- that ditch banks be reconstructed where specified including seeding of newly exposed ditch slopes
- that excavated material be levelled adjacent to the drain
- that ditch bottom and ditch slopes be cleared only (stumps are to be left) of trees, brush and scrub
- that the Municipality investigate the spraying or painting of stumps to retard future growth. If spraying or painting work is done then it is to be regarded as maintenance
- that construction access shall only be along the route of the proposed drains

RECOMMENDATIONS (cont'd)

CLOSED PORTION

- that a new 450mm to 525mm tile be constructed adjacent to the open portion of Branch "A" from Sta.0+719 to Sta.0+288
- that the above existing ditch be backfilled and graded to provide a surface waterway to accommodate excess surface water
- that a new closed drain to be known as Branch "A" upper closed portion consisting of 300mm tile (including related appurtenances) be constructed to provide a proper surface and sub-surface drainage outlet from the head of the new 450mm tile upstream into the Novastar Genetics Inc. property (40-106)
- that a rip-rap rock chute be constructed to provide erosion protection against surface water entering the ditch from the new waterway at Sta.0+775

Due to the indications of poor soil conditions our design includes the wrapping of tile joints with geotextile and a contingency allowance for crushed stone bedding wrapped with geotextile where and if necessary. These areas are typically identified at the time of construction but may only become apparent after construction is completed. In this case, the extra costs for removal and reinstallation on stone bedding would be an extra to the project and if already billed become a supplementary billing. The geotextile is required to prevent the incursion of fine soil particles into the drain and /or crushed stone bedding.

In accordance with the principals of Section 14(2) of the Drainage Act, the existing surface waterway along the route of the tile Drain shall be part of the drainage works for future maintenance. The width available for the waterway shall be equal to the maintenance working width as noted on the Contract Drawings.

We have reviewed the existing Schedule of Assessment for the Main Drain and found it to be out-of-date and unfair due to property splits and changes in the watershed and drainage conditions. We therefore recommend that when the portion of the Main Drain upstream of Branch "A" is cleaned out, that it be through an Engineer's Report. This report should include a new Schedule of Assessment for this portion of the Main Drain.

ENVIRONMENTAL CONSIDERATIONS AND MITIGATION MEASURES

We are recommending that the following erosion and sediment control measures be included as part of our reconstruction proposal to help mitigate any potential adverse impacts of the proposed drainage works on water quality and fishery habitat:

- timing of construction is to be only at times of low or no flow
- various sediment basins are to be constructed along the course of the drain at the locations specified on the plan and these basins are to be maintained by the Township of Strathroy-Caradoc

ENVIRONMENTAL CONSIDERATIONS AND MITIGATION MEASURES (cont'd)

- a temporary flow check of silt fencing is to be installed for the duration of the construction at the bottom end of the ditch cleanout
- a cleanout of the ditch bottom only has been specified so that the existing bank vegetation is not disturbed. However, where the existing banks are unstable, or may become unstable, they are to be resloped and seeded as noted on the plans
- 3 meter wide grassed buffer strips between the top of the bank and any adjacent cultivated lands on both sides of the ditch are to be incorporated and/or be constructed in accordance with the attached plans
- some existing washouts along the course of the drain are to be backfilled and protected with quarry stone rip-rap
- quarry stone rock chutes are to be constructed at surface inlet points to reduce erosion from direct surface water access into the ditch
- all new tile drain outlets are to be installed with quarry stone rip-rap protection
- some existing tile outlets along the course of the drain are to be repaired using an outlet pipe with a rodent gate with quarry stone rip-rap protection

It is to be noted that both the existing and newly vegetated banks as well as the existing natural and newly created buffer strips along each side of the ditch are permanent parts of the Parker Municipal Drain 2006 and shall not be disturbed or destroyed.

SUMMARY OF PROPOSED WORK

The proposed work consists of approximately 1338 lineal meters of open ditch cleanout including quarry stone rip-rap bank protection, rock chutes, bank seeding and sediment basins; approximately 651 lineal meters of 300mm to 525mm concrete field tile and sewer pipe including related appurtenances.

SCHEDULES

Three schedules are attached hereto and form part of this report, being Schedule 'A' - Allowances, Schedule 'B' - Cost Estimate and Schedule 'C' - Assessment for Construction.

Schedule 'A' - Allowances. In accordance with Sections 29 and 30 of the Drainage Act, allowances are provided for right-of-way and damages to lands and crops along the route of the drain as defined below.

Schedule 'B' - Cost Estimate. This schedule provides for a detailed cost estimate of the proposed work which is in the amount of \$79,500.00. This estimate includes construction, allowances, interest, engineering and administrative costs associated with this project.

allowances, interest, engineering and administrative costs associated with this project.

SCHEDULES (cont'd)

Schedule 'C' - Assessment for Construction. This schedule outlines the distribution of the total estimated cost of construction over the roads and lands which are involved.

Drawing No. 1, Our Job No. 205053 and specifications form part of this report. They show and describe in detail the location and extent of the work to be done and the lands which are affected.

ALLOWANCES

DAMAGES: Section 30 of the Drainage Act provides for the compensation to landowners along the drain for damages to lands and crops caused by the construction of the drain.

The amounts granted are based on the following:

- a) for closed drain installed with wheel machine - \$1,833.00/ha.
 - b) for backfilling ditches or those areas with topsoil stripped and relevelled - \$1,660.00/ha.
 - c) for open ditch work with excavated material levelled adjacent to drain - \$ 2,480.00/ha.
- These base rates are multiplied by the hectares derived from the working widths shown on the plans and the applicable lengths.

RIGHT-OF-WAY: Section 29 of the Drainage Act provides for an allowance to the owners whose land must be used for the construction, repair, or future maintenance of a drainage works.

For tile drains where the owners will be able to continue to use the land, the allowance provides for the right to enter upon such lands, and at various times for the purpose of inspecting such drain, removing obstructions, and making repairs. Also, the allowance provides for the restrictions imposed on those lands to protect the right-of-way from obstruction or derogation. The amounts granted for right-of-way on tile drains is based on 20% of value of the land designated for future maintenance. Therefore, the amounts granted are based on \$1,800.00/ha. through cropped lands. These values are multiplied by the hectares derived from the width granted for future maintenance and the applicable lengths.

For open ditches, the allowance provides for the loss of land due to the construction provided for in the report. The amounts granted are based on the value of the land, and the rate used was \$8,645.00/ha. When any buffer strip is incorporated and/or created, the allowance granted is for any land beyond a 1.8 meter width deemed to have always been part of the drain. For existing open ditches, the right-of-way to provide for the right to enter and restrictions imposed on those lands, is deemed to have already been granted.

ASSESSMENT DEFINITIONS

In accordance with the Drainage Act, lands that make use of a drainage works are liable for assessment for part of the cost of constructing and maintaining the system. These assessments are known as benefit, outlet liability and special benefit as set out under Sections 22,23,24 and 26 of the Act.

BENEFIT as defined in the Drainage Act means the advantages to any lands, roads, buildings or other structures from the construction, improvement, repair or maintenance of a drainage works such as will result in a higher market value or increased crop production or improved appearance or better control of surface water, or any other advantages relating to the betterment of lands, roads, buildings or other structures.

OUTLET Liability is assessed to lands or roads that may make use of a drainage works as an outlet either directly or indirectly through the medium of any other drainage works or of a swale, ravine, creek or watercourse.

SPECIAL BENEFIT is assessed to lands for which some additional work or feature has been included in the construction repair or improvement of a drainage works that has no effect on the functioning of the drainage works.

In addition, a Public Utility or Road Authority shall be assessed for and pay all the increased cost to a drainage works due to the construction and operation of the Public Utility or Road Authority. This may be shown as either benefit or special assessment.

ASSESSMENT

A modified "*Todgham Method*" was used to calculate the assessments shown on Schedule 'C' - Assessment for Construction. This entailed breaking down the costs of the drain into sections along its route. Special Assessments and Special Benefits were then extracted from each section.

The remainder is then separated into Benefit and Outlet costs. The Benefit cost is distributed to those properties receiving benefit as defined under "Assessment Definitions", with such properties usually being located along or close to the route of the drain. The Outlet Costs are distributed to all properties within the watershed area of that section on an adjusted basis. The areas are adjusted for location along that section, and relative run-off rates. Due to their different relative run-off rates, forested lands have been assessed for outlet at lower rates than cleared lands. Also, roads and residential properties, have been assessed for outlet at higher rates than cleared farm lands.

The actual cost of the work involving this report, with the exception of Special Assessments, is to be assessed on a pro-rata basis against the lands and roads liable for assessment for benefit and outlet as shown in detail on Schedule 'C' - Assessment for Construction.

SPECIAL BENEFIT ASSESSMENTS

In accordance with Section 24 of the Drainage Act, Special Benefit Assessments have been made against the following properties for their portion of the cost of various special works provided to them as detailed below:

Roll Number	Owner	Type of Work	Special Benefit Assessment
MAIN DRAIN - OPEN PORTION			
40-069	D. Skinner	Rock chute	\$ 460.00
BRANCH "A" - OPEN PORTION			
40-068	D. Skinner	Rock chutes	\$ 680.00
40-067	D. Skinner	Rock chutes Outlet pipe	\$4,450.00 \$ 640.00
40-066	P. Jarochowicz	Outlet pipe	\$ 300.00

For open drains the Contractor shall contact the owner and request that all known outlet pipes be marked by the owner prior to commencement of excavation on each property. All outlets so marked or visible or as noted on the profile, and subsequently damaged by the Contractor's operations, will be repaired by the Contractor at his cost. All other outlet pipes repaired by the Contractor under direction of the Drainage Superintendent or Engineer shall be considered an extra to the contract price. This cost (including net G.S.T.) shall be assessed to the property as a non-proratable special benefit.

SPECIAL ASSESSMENT

If any additional work is required to the drainage works due to the existence of buried utilities such as gas pipe lines, communications cables, etc. or if any of the utilities require relocation or repair, then, the extra costs incurred shall be borne by the utility involved in accordance with the provisions of Section 26 of the Drainage Act.

GRANTS

In accordance with the provisions of Section 85 of the Drainage Act, a grant **may** be available for assessments against privately owned parcels of land which are used for agricultural purposes and eligible for the Farm Property Class Tax rate. Section 88 of the Drainage Act directs the Municipality to make application for this grant upon certification of completion of this drain. The Municipality will then deduct the grant from the assessments prior to collecting the final assessments. As previously noted, no grant is available for the Branch "A" - Closed Portion (Backfilled Ditch).

MAINTENANCE

Upon completion of construction, all owners are hereby made aware of Sections 80, 82 and 83 of the Drainage Act which forbid the obstruction of, damage or injury to, and pollution of a municipal drain.

After completion, the Parker Drain 2006 shall be maintained by the Township of Strathroy-Cardoc at the expense of all upstream lands and roads assessed in Schedule 'C' - Assessment for Construction and in the same relative proportions, with the exception that all benefit assessments on the Branch "A" closed portion (backfilled ditch) be reduced by 65 percent and that all other benefit assessments be reduced by 50 percent, until such time as the assessment is changed under the Drainage Act.

Special Benefit Assessments shall only be prorated for future maintenance purposes, if the work assessed for special benefit is part of the maintenance.

Repairs or improvements to any road culvert or bridge or sub-surface road crossing required by the performance of this work and for future repair and/or replacement, shall be the responsibility of the applicable Road Authority, entirely at their cost.

The existing farm culvert on the property described by Roll No. 40-068 (Branch "A") shall be incorporated as part of this drain for future maintenance purposes. Future maintenance costs shall be levied two-thirds to the affected owner and the remainder shall be pro-rated over the upstream outlet assessments.

Respectfully submitted,

SPRIET ASSOCIATES LONDON LIMITED



M. P. DeVos, P. Eng.

sjs

SCHEDULE 'A' - ALLOWANCES

PARKER DRAIN 2006

Township of Strathroy-Caradoc

In accordance with Sections 29 and 30 of the Drainage Act, we determine the allowances payable to owners entitled thereto as follows:

CONCESSION	LOT	ROLL NUMBER (Owner)	Section 29 Right-of-Way	Section 30 Damages	TOTALS
MAIN DRAIN - OPEN PORTION					
<i>Former Township of Caradoc</i>					
5	W½ 9	40-069(D. Skinner)	\$ 1,150.00	\$ 2,230.00	\$ 3,380.00
5	SE¼ 9	40-068(D. Skinner)	40.00	130.00	170.00
Total Allowances			\$ 1,190.00	\$ 2,360.00	\$ 3,550.00
TOTAL ALLOWANCES ON THE MAIN DRAIN - OPEN PORTION					\$ 3,550.00
BRANCH "A" - OPEN PORTION					
<i>Former Township of Caradoc</i>					
4	N½ 10	40-104(Brenair Farms Inc.)	\$ 80.00	\$ 140.00	\$ 220.00
5	SE¼ 9	40-068(D. Skinner)	600.00	1,080.00	1,680.00
5	SW¼ 10	40-067(D. Skinner)	740.00	1,330.00	2,070.00
Total Allowances			\$ 1,420.00	\$ 2,550.00	\$ 3,970.00
TOTAL ALLOWANCES ON BRANCH "A" - OPEN PORTION					\$ 3,970.00
BRANCH "A" - UPPER CLOSED PORTION					
<i>Former Township of Caradoc</i>					
4	NW¼ 11	40-105(J. Ballantine)	\$ 580.00	\$ 890.00	\$ 1,470.00
4	NE¼ 11	40-106(Novastar Genetics)	25.00	65.00	90.00
Total Allowances			\$ 605.00	\$ 955.00	\$ 1,560.00
TOTAL ALLOWANCES ON BRANCH "A" - UPPER CLOSED PORTION					\$ 1,560.00
BRANCH "A" - CLOSED PORTION (Backfilled Ditch)					
<i>Former Township of Caradoc</i>					
4	N½ 10	40-104(Brenair Farms Inc.)	\$	\$ 2,150.00	\$ 2,150.00
4	NW¼ 11	40-105(J. Ballantine)		710.00	710.00
Total Allowances			\$	\$ 2,860.00	\$ 2,860.00
TOTAL ALLOWANCES ON BRANCH "A" - CLOSED PORTION (Backfilled Ditch)					\$ 2,860.00
TOTAL ALLOWANCES ON THE PARKER DRAIN 2006					\$ 11,940.00

PARKER DRAIN 2006

Township of Strathroy-Caradoc

We have made an estimate of the cost of the proposed work which is outlined in detail as follows:

MAIN DRAIN - OPEN PORTION

635 meters of open cleanout including bank resloping where specified (Approx. 80m ³)	\$	1,900.00
Levelling of excavated material	\$	400.00
Hydro-seeding of ditch banks and buffer strips (Approx. 1200m ²)	\$	540.00
Clearing and grubbing	\$	500.00
Backfill washouts, supply & install quarry stone rip-rap as rock chutes (Approx. 9.5 m ³ quarry stone required)	\$	680.00
Contingencies	\$	500.00
Allowances under section 29 & 30 of the Drainage Act	\$	3,550.00

BRANCH "A" - OPEN PORTION

703 meters of open cleanout (Approx. 270m ³) including cleaning through existing pipe culverts	\$	2,200.00
levelling of excavated material	\$	500.00
Clearing and grubbing	\$	1,500.00
Backfill washouts, supply & install quarry stone rip-rap as rock chutes (Approx. 24.5 m ³ quarry stone required)	\$	2,050.00
Supply & install two 3 meter lengths of 300mm dia., 1.6mm thickness corrugated steel outlet pipe (with rodent gate) on end of existing tiles, supply & install quarry stone rip-rap protection around pipes (approx. 4 m ³ quarry stone required)	\$	820.00
Contingencies	\$	500.00
Allowances under section 29 & 30 of the Drainage Act	\$	3,970.00

BRANCH "A" - UPPER CLOSED PORTION

Supply & Installation of the following sewer pipe and concrete field tile including wrapping of tile joints with geotextile (Approx. 200m req'd):		
188 meters of 300mm dia. concrete tile	\$	4,470.00
32 meters of 300mm dia. sewer pipe	\$	1,630.00
Contingency Allowance for the above sewer pipe or concrete tile to be installed on a crushed stone bedding due to poor soil conditions	\$	1,610.00
Tile connections and contingencies	\$	500.00
Allowances under section 29 & 30 of the Drainage Act	\$	1,560.00

PARKER DRAIN 2006
Township of Strathroy-Caradoc

BRANCH "A" - CLOSED PORTION (Backfilled Ditch)

6.0 meter length of 525mm dia. plastic sewer pipe (single piece) Supply & installation across backfilled ditch from exist. 750mm corrugated steel pipe to new 525mm concrete tile including bedding and 525mm x 750mm prefabricated eccentric reducer	\$ 570.00
Supply & Installation of the following concrete field tile including wrapping of tile joints with geotextile (Approx. 700m req'd):	
262 meters of 450mm dia. concrete tile	\$ 9,930.00
163 meters of 525mm dia. concrete tile	\$ 7,320.00
Contingency Allowance for the above sewer pipe or concrete tile to be installed crushed stone bedding due to poor soil conditions	\$ 1,610.00
Supply and install rodent gate and shot rock rip-rap protection around existing 900mm corrugated steel pipe and end of open ditch at Sta. 0+775 in accordance with detail on plan (Approx. 15m ³ shot rock req'd)	\$ 1,430.00
Clearing and grubbing	700.00
Backfilling & grading of existing ditch including preservation and releveling of topsoil	\$ 4,800.00
Tile connections as noted on plans including supply & installation of materials necessary to extend existing tiles across backfilled ditch as noted on drawing	\$ 960.00
Tile connections and contingencies	\$ 1,500.00
Allowances under section 29 & 30 of the Drainage Act	\$ 2,860.00

ADMINISTRATION

Interest	\$ 2,600.00
Survey, Plan and Final Report	\$ 11,567.00
Expenses	\$ 773.00
Supervision and Final Inspection	\$ <u>3,500.00</u>

TOTAL ESTIMATED COST **\$ 79,500.00**

SCHEDULE 'C' - ASSESSMENT FOR CONSTRUCTION

PARKER DRAIN 2006

Township of Strathroy-Caradoc

Job No. 205053

June 2, 2006

CON	LOT	HECTARES AFFECTED	ROLL No. (OWNER)	SPECIAL BENEFIT	BENEFIT	OUTLET	TOTAL				
MAIN DRAIN - OPEN PORTION											
<i>Former Township of Caradoc</i>											
3	N½ 11	6.1	40-146(Cuddy International Corp.)	\$	\$	\$ 123.00	\$ 123.00				
3	N½ 12	8.0	40-147(Novastar Genetics Inc.)			162.00	162.00				
4	S½ 9	4.4	40-114(S. Thomas)			89.00	89.00				
4	NW¼ 9	2.0	40-103-20(L. Matthys)			40.00	40.00				
* 4	Pt.N½ 9	1.2	40-103-01(G. & F. Whitney)			30.00	30.00				
4	NE¼ 9	21.6	40-103(A. & L. Matthys)			437.00	437.00				
4	SW¼ 10	12.1	40-113(M. & A. Duch)			245.00	245.00				
4	SE¼ 10	12.9	40-112(D. & N. Griffis)			261.00	261.00				
4	N½ 10	40.5	40-104(Brenair Farms Inc.)			819.00	819.00				
4	SW¼ 11	19.4	40-111(G. & G. Plaine)			393.00	393.00				
4	SE¼ 11	19.4	40-110(B. & R. Plaine)			393.00	393.00				
4	NW¼ 11	19.0	40-105(J. Ballantine)			384.00	384.00				
4	NE¼ 11	18.9	40-106(Novastar Genetics Inc.)			382.00	382.00				
* 4	Pt.NE¼ 11	0.40	40-106-10(D. & L. Cullver)			8.00	8.00				
4	S½ 12	16.2	40-109-01(J. & A. Piskorowski)			328.00	328.00				
4	N½ 12	0.8	40-107(J. Ballantine)			16.00	16.00				
5	W½ 9	20.8	40-069(D. Skinner)	460.00	5,430.00	421.00	6,311.00				
* 5	Pt.W½ 9	0.81	40-069-01(K. Evans & S. Korzeniewski)			16.00	16.00				
5	SE¼ 9	20.0	40-068(D. Skinner)		330.00	405.00	735.00				
5	SW¼ 10	17.0	40-067(D. Skinner)			344.00	344.00				
5	SE¼ 10	19.5	40-066(P. Jarochowicz)			395.00	395.00				
5	SW¼ 11	15.7	40-065(P. Jarochowicz)			318.00	318.00				
* Right-of-Way		2.9	Canadian Pacific Railway			59.00	59.00				
TOTAL ASSESSMENT ON LANDS				\$	460.00	\$	5,760.00	\$	6,068.00	\$	12,288.00
Falconbridge Dr	1.2	Township of Strathroy-Caradoc	\$	\$	\$	73.00	\$	73.00			
Century Drive	3.0	Township of Strathroy-Caradoc				182.00	182.00				
Sutherland Road	1.6	Township of Strathroy-Caradoc			200.00	97.00	297.00				
TOTAL ASSESSMENT ON ROADS				\$	\$	200.00	\$	352.00	\$	552.00	
TOTAL ASSESSMENT ON THE MAIN DRAIN - OPEN PORTION							\$	12,840.00			

SCHEDULE 'C' - ASSESSMENT FOR CONSTRUCTION (Cont'd)

PARKER DRAIN 2006
Township of Strathroy-Caradoc

CON	LOT	HECTARES AFFECTED	ROLL No. (OWNER)	SPECIAL BENEFIT	BENEFIT	OUTLET	TOTAL	
BRANCH "A" - OPEN PORTION								
<i>Former Township of Caradoc</i>								
4	N½ 10	21.9	40-104(Brenair Farms Inc.)	\$	\$ 130.00	\$ 1,597.00	\$ 1,727.00	
4	NW¼ 11	19.0	40-105(J. Ballantine)			1,320.00	1,320.00	
4	NE¼ 11	18.9	40-106(Novastar Genetics Inc.)			1,233.00	1,233.00	
* 4	Pt.NE¼ 11	0.40	40-106-10(D. & L. Cullver)			44.00	44.00	
4	SE¼ 11	1.2	40-110(B. & R. Plaine)			88.00	88.00	
4	N½ 12	0.8	40-107(J. Ballantine)			58.00	58.00	
5	SE¼ 9	7.9	40-068(D. Skinner)	680.00	1,170.00	173.00	2,023.00	
5	SW¼ 10	17.0	40-067(D. Skinner)	5,090.00	960.00	826.00	6,876.00	
5	SE¼ 10	19.5	40-066(P. Jarochowicz)	300.00		808.00	1,108.00	
5	SW¼ 11	15.7	40-065(P. Jarochowicz)			674.00	674.00	
* Right-of-Way		0.4	Canadian Pacific Railway			73.00	73.00	
TOTAL ASSESSMENT ON LANDS				\$	6,070.00	\$ 2,260.00	\$ 6,894.00	\$ 15,224.00
Century Drive 2.2 Township of Strathroy-Caradoc					360.00	\$ 350.00	\$ 456.00	\$ 1,166.00
TOTAL ASSESSMENT ON ROADS				\$	360.00	\$ 350.00	\$ 456.00	\$ 1,166.00
TOTAL ASSESSMENT ON BRANCH "A" - OPEN PORTION							\$ 16,390.00	
BRANCH "A" - UPPER CLOSED PORTION								
<i>Former Township of Caradoc</i>								
4	NW¼ 11	5.0	40-105(J. Ballantine)	\$	6,060.00	\$ 793.00	\$ 6,853.00	
4	NE¼ 11	18.9	40-106(Novastar Genetics Inc.)		740.00	3,831.00	4,571.00	
* 4	Pt.NE¼ 11	0.4	40-106-10(D. & L. Cullver)			136.00	136.00	
4	SE¼ 11	1.2	40-110(B. & R. Plaine)			136.00	136.00	
4	N½ 12	0.8	40-107(J. Ballantine)			181.00	181.00	
* Right-of-Way		0.4	Canadian Pacific Railway			227.00	227.00	
TOTAL ASSESSMENT ON LANDS				\$	6,800.00	\$ 5,304.00	\$ 12,104.00	
Century Drive 0.5 Township of Strathroy-Caradoc				\$		\$ 256.00	\$ 256.00	
TOTAL ASSESSMENT ON ROADS				\$		\$ 256.00	\$ 256.00	
TOTAL ASSESSMENT ON BRANCH "A" - UPPER CLOSED PORTION							\$ 12,360.00	

SCHEDULE 'C' - ASSESSMENT FOR CONSTRUCTION (Cont'd)

PARKER DRAIN 2006
Township of Strathroy-Caradoc

CON	LOT	HECTARES AFFECTED	ROLL No. (OWNER)	BENEFIT	OUTLET	TOTAL
BRANCH "A" - CLOSED PORTION (Backfilled Ditch)						
<i>Former Township of Caradoc</i>						
4	N½ 10	15.3	40-104(Brenair Farms Inc.)	\$ 23,387.00	\$ 1,277.00	\$ 24,664.00
4	NW¼ 11	19.0	40-105(J. Ballantine)	7,573.00	2,114.00	9,687.00
4	NE¼ 11	18.9	40-106(Novastar Genetics Inc.)		2,819.00	2,819.00
* 4	Pt.NE¼ 11	0.4	40-106-10(D. & L. Cullver)		100.00	100.00
4	SE¼ 11	1.2	40-110(B. & R. Plaine)		100.00	100.00
4	N½ 12	0.8	40-107(J. Ballantine)		133.00	133.00
* Right-of-Way		0.4	Canadian Pacific Railway		167.00	167.00
TOTAL ASSESSMENT ON LANDS				\$ 30,960.00	\$ 6,710.00	\$ 37,670.00
Century Drive				\$	\$ 240.00	\$ 240.00
TOTAL ASSESSMENT ON ROADS				\$	\$ 240.00	\$ 240.00
TOTAL ASSESSMENT ON BRANCH "A" - CLOSED PORTION (Backfilled Ditch)						\$ <u>37,910.00</u>
TOTAL ASSESSMENT ON THE PARKER DRAIN 2006						\$ <u>79,500.00</u>

NOTE: All of the above lands, with the exception of those noted with an asterisk, are classified as agricultural.

SCHEDULE OF NET ASSESSMENT

PARKER DRAIN 2006
Township of Strathroy-Caradoc

(FOR INFORMATION PURPOSES ONLY)

Job No. 205053

June 2, 2006

ROLL NUMBER (OWNER)	CLOSED PORTION BACKFILLED DITCH	OPEN & UPPER CLOSED PORTIONS	TOTAL ASSESSMENT	OPEN & UPPER CLOSED PORTIONS GRANT	ALLOW.	APPROX. NET
40-146(Cuddy International Corp.)	\$	123.00	\$ 123.00	\$ 41.00	\$	82.00
40-147(Novastar Genetics Inc.)		162.00	162.00	54.00		108.00
40-114(S. Thomas)		89.00	89.00	30.00		59.00
40-103-20(L. Matthys)		40.00	40.00	13.00		27.00
* 40-103-01(G. & F. Whitney)		30.00	30.00			30.00
40-103(A. & L. Matthys)		437.00	437.00	146.00		291.00
40-113(M. & A. Duch)		245.00	245.00	82.00		163.00
40-112(D. & N. Griffis)		261.00	261.00	87.00		174.00
40-104(Brenair Farms Inc.)	24,664.00	2,546.00	27,210.00	849.00	2,370.00	23,991.00
40-111(G. & G. Plaine)		393.00	393.00	131.00		262.00
40-105(J. Ballantine)	9,687.00	8,557.00	18,244.00	2,852.00	2,180.00	13,212.00
40-106(Novastar Genetics Inc.)	2,819.00	6,186.00	9,005.00	2,062.00	90.00	6,853.00
* 40-106-10(D. & L. Cullver)	100.00	188.00	288.00			288.00
40-110(B. & R. Plaine)	100.00	617.00	717.00	206.00		511.00
40-109-01(J. & A. Piskorowski)		328.00	328.00	109.00		219.00
40-107(J. Ballantine)	133.00	255.00	388.00	85.00		303.00
40-069(D. Skinner)		6,311.00	6,311.00	2,104.00	3,380.00	827.00
* 40-069-01(K. Evans & S. Korzeniewski)		16.00	16.00			16.00
40-068(D. Skinner)		2,758.00	2,758.00	919.00	1,850.00	(11.00)
40-067(D. Skinner)		7,220.00	7,220.00	2,407.00	2,070.00	2,743.00
40-066(P. Jarochowicz)		1,503.00	1,503.00	501.00		1,002.00
40-065(P. Jarochowicz)		992.00	992.00	331.00		661.00
* Canadian Pacific Railway	167.00	359.00	526.00			526.00
Falconbridge Dr.		73.00	73.00			73.00
Century Drive	240.00	1,604.00	1,844.00			1,844.00
Sutherland Road		297.00	297.00			297.00
TOTALS	\$ 37,910.00	\$ 41,590.00	\$ 79,500.00	\$ 13,009.00	\$ 11,940.00	\$ 54,551.00

**SPECIFICATIONS FOR CONSTRUCTION
OF
MUNICIPAL DRAINAGE WORKS**

GENERAL INDEX

SECTION A	General Conditions	Pages 1 to 8
SECTION B	Open Drain	Pages 9 to 11
SECTION C	Tile Drain	Pages 12 to 17
SECTION D	Municipal Drains Crossing County Roads	Pages 18 to 19
STANDARD DETAILED DRAWINGS		SDD-01 to SDD-05



SECTION A - GENERAL CONDITIONS

INDEX

<u>SECTION NUMBER</u>	<u>PAGE NO.</u>
A.1 SCOPE	1
A.2 TENDERS	1
A.3 DRAWINGS AND SPECIFICATIONS	1
A.4 PAYMENT	1
A.5 SUPERINTENDENT	1
A.6 COMMENCEMENT AND COMPLETION OF WORK	2
A.7 WORKING AREA AND ACCESS	2
.....	
A.8 SUPERVISION	2
A.9 INSPECTION	2
A.10 ALTERATIONS AND ADDITIONS.....	2
A.11 MAINTENANCE	3
A.12 INSURANCE	3
A.13 LIMITATIONS OF OPERATIONS	3
.....	
A.14 LOSSES	3
A.15 SUB-CONTRACTORS	3
A.16 PERMITS, NOTICES, LAWS AND RULES	3
A.17 ROAD CROSSINGS	4
A.18 JACKING AND BORING	4
A.19 FENCES	5
A.20 LIVESTOCK	5
A.21 STANDING CROPS	5
A.22 SURPLUS GRAVEL	5
A.23 RAILWAYS, HIGHWAYS, UTILITIES	6
A.24 LOCATION OF UTILITIES	6
A.25 TERMINATION OF CONTRACT BY THE MUNICIPALITY	6
.....	
A.26 ERRORS AND UNUSUAL CONDITIONS.....	6
A.27 IRON BARS	7
A.28 STAKES	7
A.29 RIP-RAP	7
A.30 GABION BASKETS	7
A.31 RESTORATION OF LAWNS	7
A.32 RESTORATION OF ROADS AND LANEWAYS	8

SECTION A
GENERAL CONDITIONS

A.1 SCOPE

The work to be done under this specification consists of supplying all labour, materials and equipment to construct the work as outlined on the drawing(s). In some Municipalities, the Contractor shall supply all materials while in other Municipalities, he shall supply only certain materials. The form of Tender and Agreement lists which materials are to be supplied by the Contractor.

A.2 TENDERS

Tenders are to be submitted on a lump sum basis for the complete works or a portion thereof, as set out in the Form of Tender and Agreement.

A.3 DRAWINGS AND SPECIFICATIONS

The tenderer must satisfy himself that he understands the meaning and intent of the drawings and specifications before submission of his tender. The standard specifications have been separated into sections for reference purpose only. They shall be considered complementary and, where a project is controlled under one of the sections, the remaining sections will still apply for miscellaneous works. In case of any inconsistency or conflict in the Tender Documents, the following order of precedence shall apply:

- Contract Drawings
- Form of Tender and Agreement
- General Conditions
- Standard Specifications (Open Drain, Tile Drain, Specifications for Municipal Drain Crossing County Roads)
- Standard Drawings

A.4 PAYMENT

Progress payments equal to 87±% of the value of the work done and materials incorporated in the work will be made to the Contractor on the written request of the Contractor to the Engineer. An additional 10±% will be paid 45 days after the final acceptance by the Engineer. Before this payment is released, the Contractor shall provide the Municipality with a Statutory Declaration that all material and/or labour incorporated in the work has been fully paid for, along with a Certificate of Clearance from the Workplace Safety and Insurance Board stating that all compensation has been paid. The Municipality will reserve 3%± of the Contract Price for one year as warranty. After the completion of the work, any part of this reserve may be used to correct defects which may develop within that time from faulty workmanship or material or loose backfill, provided that notice shall first be given to the Contractor and that he may promptly make good such defects, if he desires.

A.5 SUPERINTENDENT

The word "Superintendent", as used hereinafter in these specifications, shall refer to a Drainage Superintendent, appointed by the Municipality. The Superintendent will act as the Engineer's representative. The Superintendent shall have the power to direct the execution of the work and to make any necessary minor adjustments. Adjustments in tile sizes or gradients shall not be made without the approval of the Engineer. Any instructions given by the Superintendent, which changes considerably the proposed work or with which the Contractor does not agree, shall be referred to the Engineer for his decision.

A.6 COMMENCEMENT AND COMPLETION OF WORK

The work must commence immediately after the Contractor is notified of the acceptance of his tender or at a later date, if set out as a condition of the tender. If weather creates poor ground or working conditions, the Contractor may be required, at the discretion of the Engineer, to postpone or halt work until conditions become acceptable.

The Contractor shall give the Engineer and Superintendent a minimum of forty-eight (48) hours notice before commencement of work on any municipal drain. As noted on the plan, he can then arrange for a meeting to be held on the site with the Contractor and affected owners attending to review in detail the construction scheduling and other details. The Contractor's costs for attending this meeting shall be included in his lump sum tender price. If the Contractor leaves the job site for a period of time after initiation of work, he shall give the Engineer and the Superintendent a minimum of twenty-four (24) hours notice prior to returning to the project.

The work must be proceeded with in such a manner as to ensure its completion at the earliest possible date and within the time limit set out in the tender or in the contract documents.

A.7 WORKING AREA AND ACCESS

The working area available to the Contractor to construct the drain and related works including an access route to the drain shall be as specified on the drawings.

Should the specified widths become inadequate due to unusual conditions, the Contractor shall notify the Engineer immediately in order that negotiations with the affected owners can take place.

Where a Contractor exceeds the specified widths due to the nature of his operations and without authorization he shall be held responsible for the costs of all additional damages and the amount shall be deducted from his contract price and paid to the affected owners by the Municipality.

A.8 SUPERVISION

The Contractor shall give the work his constant supervision and shall keep a competent foreman in charge at the site.

A.9 INSPECTION

Final inspection by the Engineer will be made within twenty days after he has received notice in writing from the Contractor that the work is complete.

Periodic inspections by the Engineer or Superintendent will be made during the performance of the work. These interim inspections are required to check such items as location of drainage course and structures, tile grades prior to backfilling, backfilling and miscellaneous work items.

A.10 ALTERATIONS AND ADDITIONS

The Engineer shall have the power to make alterations in the work shown or described in the drawings or specifications and the Contractor shall proceed to make such changes without causing delay. In every such case, the price agreed to be paid for the work under the contract shall be increased or decreased as the case may require according to a fair and reasonable valuation of the work added or deleted. The valuation shall be determined as a result of negotiations between the Superintendent, the Contractor, and the Engineer, but in all cases, the Engineer shall maintain the final responsibility for the decision. Such alterations and variations shall in no way render void the contract. No claim for variations or alterations in the increased or decreased price shall be valid unless done in pursuance of an order from the Engineer and/or Superintendent and notice of such claims made in writing before commencement of such work. In no case shall the Contractor commence work which he considers to be extra work before receiving the Engineer's and/or Superintendent's approval in writing.

A.11 MAINTENANCE

The Contractor shall repair and make good any damages or faults in the drain that may appear within one year after its completion (as dated on the final completion certificate) as the result of imperfect or defective work done or materials furnished by the Contractor. Nothing herein contained shall be construed as in any way restricting or limiting the liability of the Contractor under the laws of the Country, Province or Locality in which the work is being done.

A.12 INSURANCE

- 1) Bodily Injury Liability: The Contractor shall effect and maintain, a Comprehensive General Liability Policy or its equivalent, covering claims for bodily injury, including death arising from and during operations under his Contract whether performed by himself, by a sub-contractor or by anyone directly or indirectly employed by either of them in the sum of \$ 2,000,000.00.
- 2) Property Damage: The Contractor shall effect and maintain Property Damage Liability Insurance to cover his and the sub-contractor's operations in the sum of \$ 1,000,000.00.
- 3) Fire Insurance: The Contractor shall procure fire and extended coverage insurance on the work to 100% of the Contract Amount.
- 4) The following are to be named as co-insured:
 - Successful Contractor
 - Sub-Contractor
 - Municipality
 - Spriet Associates London Limited
- 5) Within 7 days of award of Contract and prior to commencing work, the successful Contractor shall file with the Municipality, a copy of each insurance policy and certificate required. All such insurance shall be maintained until final completion of the work including the making good of faulty work or materials; except that coverage of completed operations liability shall in any event be maintained for twelve (12) months from the date of final completion as certified by the Engineer.

A.13 LIMITATIONS OF OPERATIONS

Except for such work as may be required by the Engineer to maintain the works in a safe and satisfactory condition, the Contractor shall not carry on his operations under the contract on Sundays without permission in writing of the Municipality.

A.14 LOSSES

The Contractor shall take all risks from floods or casualties of any kind.

A.15 SUB-CONTRACTORS

The Contractor shall not sublet the whole or any part of the contract without the approval of the Engineer or Superintendent.

A.16 PERMITS, NOTICES, LAWS AND RULES

The Contractor shall ensure that all necessary permits or licences required for the execution of the work have been obtained (but this shall not include M.T.O. encroachment permits, permanent easements or rights of servitude). The Contractor shall give all necessary notices and pay all fees required by law and comply with all laws, ordinances, rules and regulations (including the Occupational Health and Safety Act) relating to the work and to the preservation of the public's health and safety and if the specifications and drawings are at variance therewith, any resulting additional expenses incurred by the Contractor shall constitute an addition to the contract price.

A.17 **ROAD CROSSINGS**

- .1 **Scope:** Where a road crossing is a requirement of the contract, the Contractor shall include in his lump sum price for the supply of all labour, equipment and materials to complete the work unless otherwise specified. For Highway, Regional or County Road crossings, see "Specifications for Municipal Drains Crossing County Roads".
- .2 **Notification:** The Contractor shall give the Municipal Road Authority a minimum of 48 hours (exclusive of Saturday, Sunday or Holidays) prior to proceeding with any work on road property. The Contractor shall be responsible for notification of all applicable authorities (Police, Fire, Ambulance, School Board, etc.) at least 72 hours prior to construction.
- .3 **Traffic Control:** Unless authorized by the Road Authority, the Contractor shall keep the road open to traffic at all times. The Contractor shall provide, for the supply, erection and maintenance, suitable warning signs and/or flagmen in accordance with the Manual of Uniform Traffic Control Devices and to the satisfaction of the Road Authority to notify the motorists of work on the road ahead. Where the Contractor is permitted to close the road to through traffic, the Contractor shall provide for and adequately sign the detour route to the satisfaction of the Road Authority.

A.18 **JACKING AND BORING**

- .1 **Material:** The bore pipe shall consist of new, smooth wall steel pipe, meeting the requirements of H20 loading for road crossings and E80 loading for railway crossings. The minimum size, wall thickness and length shall be as shown on the drawings. Where welding is required, the entire circumference of any joint shall be welded using currently accepted welding practices.
- .2 **Site Preparation and Excavation:** Where necessary, fences shall be carefully taken down as specified in the General Conditions. Prior to any excavation taking place, all areas which will be disturbed shall be stripped of topsoil. The topsoil is to be stockpiled in locations away from the bore operation, off the line of future tile placement and out of existing water runs or ditches. The bore pit shall be located at the upstream end of the bore unless otherwise specified or approved.
- .3 **Installation:** The pipe shall be installed in specified line and grade by a combination of jacking and boring. Upon completion of the operations, both ends of the bore pipe shall be left uncovered until the elevation has been confirmed by the Engineer or Superintendent. The ends of the bore pipe shall be securely blocked off and the location marked by means of a stake extending from the pipe invert to 300mm above the surrounding ground surface.
- .4 **Unstable Soil or Rock:** The Contractor shall contact the Engineer immediately should unstable soil be encountered or if boulders of sufficient size and number to warrant concern are encountered. Any bore pipe partially installed shall be left in place until alternative methods or techniques are determined by the Engineer after consultation with the Contractor, the Superintendent and the owning authority.
- .5 **Tile Connections:** Prior to commencement of backfilling, all tile encountered in excavations shall be reconnected using material of a size comparable to the existing material. Where the excavation is below the tile grade, a compacted granular base is to be placed prior to laying the tile. Payment for each connection will be made at the rate outlined in the Form of Tender and Agreement.
- .6 **Backfill:** Unless otherwise specified, the area below the proposed grade shall be backfilled with a crushed stone bedding with remainder backfilled with on-site material and thoroughly compacted. Surplus material from the boring operation shall be removed from the site at the Contractor's expense.

A.18 **JACKING AND BORING** (cont'd)

- .7 **Restoration**: The entire affected area shall be shaped and graded to original lines and grades, the topsoil replaced, and the area seeded down at the rate of 85 kg/per ha. unless otherwise specified or in accordance with the M.T.O. Encroachment Permit. Fences shall be restored to their original condition in accordance with the General Conditions.
- .8 **Acceptance**: All work undertaken by the Contractor shall be to the satisfaction of the Engineer.

A.19 **FENCES**

No earth shall be placed against fences and all fences removed by the Contractor are to be replaced by him in as good condition as found. In general, the Contractor will not be allowed to cut existing fences but shall disconnect existing fences at the nearest anchor post or other such fixed joint and shall carefully roll it back out of the way. Where the distance to the closest anchor post or fixed joint exceeds 50 meters, the Contractor will be allowed to cut and splice in accordance with accepted methods and to the satisfaction of the owner and the Engineer or Superintendent. Where existing fences are deteriorated to the extent that existing materials are not salvageable for replacement, the Contractor shall notify the Engineer or the Superintendent prior to dismantling. Fences damaged beyond salvaging by the Contractor's negligence shall be replaced with new materials, similar to those existing, at the Contractor's expense. The replacement of the fences shall be done to the satisfaction of the owner and the Engineer or Superintendent. The site examination should indicate to the Contractor such work, if any, and an allowance should be made in the tendered price.

The Contractor shall not leave any fence open when he is not at work in the immediate vicinity.

A.20 **LIVESTOCK**

The Contractor shall provide each property owner with 48 hours notice prior to removing any fences along fields which could possibly contain livestock. Thereafter, the property owner shall be responsible to keep all livestock clear of the construction areas until further notified. Where necessary, the Contractor will be directed to erect temporary fences. The Contractor shall be held responsible for loss or injury to livestock or damage caused by livestock, where the injury or damage is caused by his failure to notify the property owner or through negligence or carelessness on the part of the Contractor.

The Contractor constructing a tile drain shall not be held responsible for damages or injury to livestock occasioned by leaving trenches open for inspection by the Engineer if he notifies the owner at least 48 hours prior to commencement of the work on that portion. The Contractor will be held liable for such damages or injury if the backfilling of such trenches is delayed more than 1 day after acceptance by the Engineer.

A.21 **STANDING CROPS**

The Contractor shall not be held responsible for damages to standing crops within the working area available and the access route provided if he notifies the owner thereof at least 48 hours prior to commencement of the work on that portion.

A.22 **SURPLUS GRAVEL**

If as a result of any work, gravel or crushed stone is required and not all the gravel or crushed stone is used in the construction of the works, the Contractor shall haul away such surplus gravel or stone unless otherwise approved.

A.23 RAILWAYS, HIGHWAYS, UTILITIES

A minimum of forty-eight (48) hours notice to Railways, Highways and Utilities, exclusive of Saturdays, Sundays and Holidays, shall be required by the Contractor prior to any work being performed and in the case of a pipe being installed by open cutting or boring under a Highway or Railway, a minimum of 72 hours notice is required.

A.24 UTILITIES

The attention of the Contractor is drawn to the presence of utilities along the course of the drain. The Contractor will be responsible for determining the location of all utilities and will be held liable for any damage to all utilities caused by his operations. The Contractor shall co-operate with all authorities to ensure that all utilities are protected from damage during the performance of the work. The cost of any necessary relocation work shall be borne by the utility. No allowance or claims of any nature will be allowed on account for delays or inconveniences due to utilities relocation, or for inconveniences and delays caused by working around or with existing utilities not relocated.

A.25 TERMINATION OF CONTRACT BY THE MUNICIPALITY

If the Contractor should be adjudged bankrupt, or if he should make a general assignment for the benefit of his creditors, or if a receiver should be appointed on account of his insolvency, or if he should refuse or fail to supply enough properly skilled workmen or proper materials after having received seven (7) days notice in writing from the Engineer to supply additional workmen or materials, or if he should fail to make prompt payment to subcontractors or for material or labour or persistently disregarding laws, ordinances, or the instruction of the Engineer, or otherwise being guilty of a substantial violation of the provisions of the contract, then the Municipality, upon the certification of the Engineer that sufficient cause exists to justify such action, may without prejudice to any other right or remedy, by giving the contractor written notice, terminate the employment of the contractor and take possession of the premises and of all materials, tools and appliances, thereon, and complete the work by whatever method the Engineer may deem expedient, but without undue delay or expense. In such case, the Contractor shall not be entitled to receive any further payment until the work is completed. If the unpaid balance of the contract price exceeds the expense of completing the work, including compensation to the Engineer for his additional services, such excess shall be paid to the Contractor. If such expense does not exceed such unpaid balance, the Contractor shall pay the difference to the Municipality. The expense incurred by the Municipality, as herein provided, shall be certified by the Engineer. Where a Contractor fails to commence work within seven (7) days of his commencement date as indicated by him on his Tender Form, and such extension of time as allowed due to poor weather or ground conditions, then the Municipality shall have the option, after providing the Contractor with seven (7) days notice of their intention to terminate the contract, award the contract to another Contractor at their discretion by retendering the project, inviting bids or by appointment. The additional costs of the above or retendering, and all other administration costs shall be deducted from the Contractor's bid deposit and the balance, if any, returned to him.

A.26 ERRORS AND UNUSUAL CONDITIONS

The Contractor shall notify the Engineer immediately of any error or unusual condition which may be found. Any attempt by the Contractor to make changes because of the error or unusual condition on his own shall be done at his own risk. Any additional cost incurred by the Contractor to remedy a wrong decision on his part shall be borne by the Contractor.

The Engineer shall make the alteration necessary to correct errors or to adjust for unusual conditions during which time it will be the Contractor's responsibility to keep his men and equipment gainfully employed elsewhere on the project. The contract amount shall be adjusted in accordance with a fair evaluation of the work added or deleted.

A.27 **IRON BARS**

The Contractor shall be held liable for the cost of an Ontario Land Surveyor to replace any iron bars destroyed during the course of construction.

A.28 **STAKES**

At the time of the survey, stakes are set along the course of the drain at intervals of 50 meters. The Contractor shall ensure that the stakes are not disturbed unless approval is obtained from the Engineer. Any stakes removed by the Contractor without the authority of the Engineer, shall be replaced at the expense of the Contractor. At the request of the Contractor, any stakes which are removed or disturbed by others or by livestock, shall be replaced at the expense of the drain.

A.29 **RIP-RAP**

Rip-rap shall be specified on the drawings and shall conform to the following:

- .1 **Quarry Stone**: shall range in size from 150mm to 300mm evenly distributed and shall be placed to a 300mm thickness on a filter blanket at a 1.5 : 1 slope unless otherwise noted. Filter blanket to be Mirafi 160N or approved equal.
- .2 **Broken Concrete**: may be used in areas outside of regular flows if first broken in maximum 450mm sized pieces and mixed to blend with quarry stone as above. No exposed reinforcing steel shall be permitted.
- .3 **Shot Rock**: shall range in size from 150mm to 600mm placed to a depth of 450mm thickness on a filter blanket at a 1.5:1 slope unless otherwise noted. Filter blanket to be Mirafi 160N or approved equal.

A.30 **GABION BASKETS**

Supply and install gabion basket rip-rap protection as shown on the drawings.

Gabion baskets shall be as manufactured by Maccaferri Gabions of Canada Ltd. or approved equal and shall be assembled and installed in strict accordance with the manufacturer's recommendations.

The gabion fill material shall consist solely of fractured field stone or gabion stone graded in size from 100mm to 200mm (4" to 8") and shall be free of undersized fragments and unsuitable material.

A.31 **RESTORATION OF LAWNS**

- .1 **General**: Areas noted on the drawings to be restored with seeding or sodding shall conform to this specification, and the contractor shall allow for all costs in his lump sum bid for the following works.
- .2 **Topsoil**: Prior to excavation, the working area shall be stripped of existing topsoil. The topsoil stockpile shall be located so as to prevent contamination with material excavated from the trench. Upon completion of backfilling operations, topsoil shall be spread over the working area to a depth equal to that which previously existed but not less than the following:

Seeding and sodding	-	minimum depth of 100mm
Gardens	-	minimum depth of 300mm

In all cases where a shortfall of topsoil occurs, whether due to lack of sufficient original depth or rejection of stockpiled material due to contractors operations, imported topsoil from acceptable sources shall be imported at the contractors expense to provide the specified depths. Topsoil shall be uniformly spread, graded and cultivated prior to seeding or sodding. All clods or lumps shall be pulverized and any roots or foreign matter shall be raked up and removed as directed.

A.31 RESTORATION OF LAWNS (cont'd)

.3 Sodding

- .1 **Materials:** Nursery sod to be supplied by the contractor shall meet the current requirements of the Ontario Sod Growers Association for No. 1 Bluegrass Fescue Sod.
- .2 **Fertilizer:** Prior to sod placement, approved fertilizer shall be spread at the rate of 5kg/100m² of surface area and shall be incorporated into such surfaces by raking, discing or harrowing. All surfaces on which sod is to be placed shall be loose at the time of placing sod to a depth of 25mm.
- .3 **Placing Sod:** Sod shall be laid lengthwise across the face of slopes with ends close together. Sod shall be counter sunk along the joints between the existing grade and the new sodding to allow for the free flow of water across the joint. Joints in adjacent rows shall be staggered and all joints shall be pounded and rolled to a uniform surface.

On slopes steeper than 3:1, and in unstable areas, the engineer may direct the contractor to stake sod and/or provide an approved mesh to prevent slippages. In all cases where such additional work is required, it will be deemed an extra to the contract and shall be paid for in accordance with the General Conditions.

No sod shall be laid when frozen nor upon frozen ground nor under any other condition not favourable to the growth of the sod. Upon completion of sod laying the contractor shall thoroughly soak the area with water to a depth of 50mm. Thereafter it will be the responsibility of the property owner to maintain the area in a manner so as to promote growth.

- .4 **Seeding:** Seed to be supplied by the contractor shall be "high quality grass seed" harvested during the previous year, and shall be supplied to the project in the suppliers original bags on which a tag setting out the following information is affixed:

- Year or Harvest - recommended rate of application
- Type of Mixture - fertilizer requirements

Placement of seed shall be by means of an approved mechanical spreader. All areas on which seed is to be placed shall be loose at the time of placing seed, to a depth of 25mm. Seed and fertilizer shall be spread in accordance with the suppliers recommendations unless otherwise directed by the Engineer. Thereafter it will be the responsibility of the property owner to maintain the area in a manner so as to promote growth.

- .5 **Settlement:** The contractor shall be responsible during the one year guarantee period for the necessary repair of restored areas due to trench settlement. Areas where settlement does not exceed 50mm may be repaired by top dressing with fine topsoil. In areas where settlement exceeds 50mm, the contractor will be required to backfill the area with topsoil and restore with seeding and/or sodding as originally specified.

A.32 RESTORATION OF ROADS AND LANEWAYS

- .1 **Gravel:** Restoration shall be in accordance with the applicable standard detailed drawing or as shown on the drawings.
- .2 **Asphalt and Tar and Chip:** Prior to restoration all joints shall be neatly sawcut. Restoration shall be as a in gravel above with the addition of the following:
 - .1 Roads shall have the finished grade of Granular 'A', allow two courses of hot-mix asphalt (M.T.O. 310), 80mm HL6 and 40mm HL3 or to such greater thickness as may be required to match the existing.
 - .2 Laneways shall have the finished grade of Granular 'A' allow one 50mm minimum course of hot-mix asphalt (HL3) or greater as may be required to match existing.

SECTION B - OPEN DRAIN

INDEX

<u>SECTION NUMBER</u>		<u>PAGE NUMBER</u>
B.1	PROFILE.....	9
B.2	ALIGNMENT.....	9
B.3	CLEARING AND GRUBBING.....	9
B.4	EXCAVATION.....	9
B.5	EXCAVATED MATERIAL.....	10
B.6	EXCAVATION THROUGH BRIDGES AND CULVERTS.....	10
B.7	PIPE CULVERT.....	10
B.8	MOVING DRAINS OFF ROADS.....	10
B.9	TRIBUTARY OUTLETS.....	11
B.10	SEDIMENT BASINS AND TRAPS.....	11
B.11	SEEDING.....	11

SECTION B

OPEN DRAIN

B.1 PROFILE

The profile drawing shows the depth of cuts from the ground beside the stake to the final invert of the ditch in meters and decimals of a meter and also the approximate depth of cuts from the existing bottom of the ditch to the elevation of the ditch bottom. These cuts are established for the convenience of the Contractor; however, bench marks will govern the final elevation of the drain. Bench marks have been established along the course of the drain and their locations and elevations are noted on the profile drawing. A uniform grade shall be maintained between stakes in accordance with the profile drawing.

B.2 ALIGNMENT

The drain shall be constructed in a straight line and shall follow the course of the present drain or water run unless otherwise noted on the drawings. Where it is necessary to straighten any bends or irregularities in alignment not noted on the drawings, the Contractor shall contact the Engineer or Superintendent before commencing the work.

B.3 CLEARING AND GRUBBING

Prior to commencement of work, all trees, scrub, fallen timber and debris shall be removed from the side slopes of the ditch and for such a distance on the working side so as to eliminate any interference with the construction of the drain or the spreading of the spoil. The side slopes shall be neatly cut and cleared flush with slope whether or not they are affected directly by the excavation. With the exception of large stumps causing damage to the drain, the sideslope shall not be grubbed. All other cleared areas shall be grubbed and the stumps put into piles for disposal by the owner.

All trees or limbs 150mm (6") or larger, that it is necessary to remove, shall be considered as logs and shall be cut and trimmed, and left in the working width separate from the brush, for use or disposal by the owner. Trees or limbs less than 150mm in diameter shall be cut in lengths not greater than 5 meters and placed in separate piles with stumps spaced not less than 75 meters apart in the working width, for the use or disposal of the owner. In all cases, these piles shall be placed clear of excavated materials, and not be piled against standing trees. No windrowing will be permitted. The clearing and grubbing and construction of the drain are to be carried out in two separate operations and not simultaneously at the same location.

B.4 EXCAVATION

The bottom width and the side slopes of the ditch shall be those shown on the profile drawing.

Unless otherwise specified on the drawings, only the existing ditch bottom is to be cleaned out and the side slopes are not to be disturbed. Where existing side slopes become unstable because of construction, the Contractor shall immediately contact the Engineer or Superintendent. Alternative methods of construction and/or methods of protection will then be determined, prior to continuing the work.

Where an existing drain is being relocated or where a new drain is being constructed, the Contractor shall, unless otherwise specified, strip the topsoil for the full width of the drain, including the location of the spoil pile. Upon completion of levelling, the topsoil shall be spread to an even depth across the full width of the spoil.

B.5 EXCAVATED MATERIAL

Excavated material shall be deposited on either or both sides of the drain as indicated on the drawings or as directed by the Engineer or Superintendent. A buffer strip of not less than 3 meters in width through farmed lands and 2 meters in width through bush areas shall be left along the top edges of the drain. The buffer strip shall be seeded and/or incorporated as specified on the drawings. The material shall be deposited beyond the specified buffer strip.

No excavated material shall be placed in tributary drains, depressions, or low areas which direct water into the ditch so that water will be trapped behind the spoilbank. The excavated material shall be placed and levelled to a minimum width to depth ratio of 50:1 unless instructed otherwise. The edge of the spoilbank away from the ditch shall be feathered down to the existing ground; the edge of the spoilbank nearest the ditch shall have a maximum slope of 2 to 1. The material shall be levelled such that it may be cultivated with ordinary farm equipment without causing undue hardship on machinery and personnel. No excavated material shall cover any logs, scrub, debris, etc. of any kind.

Where it is necessary to straighten any unnecessary bends or irregularities in the alignment of the ditch, the excavated material from the new cut shall be used for backfilling the original ditch. Regardless of the distance between the new ditch and the old ditch no extra compensation will be allowed for this work and must be included in the Contractor's lump sum price for the open work.

Any stones 150mm or larger left exposed on top of the levelled excavated material shall be removed and disposed of as an extra to the contract unless otherwise noted on plans.

B.6 EXCAVATION THROUGH BRIDGES AND CULVERTS

The Contractor shall excavate the drain to the full specified depth and width under all bridges. Where the bridge or culvert pipe is located within a road allowance, the excavated material shall be levelled within the road allowance. Care shall be taken not to adversely affect existing drainage patterns. Temporary bridges may be carefully removed and left on the bank of the drain but shall be replaced by the Contractor when the excavation is completed unless otherwise specified. Permanent bridges must be left intact. All necessary care and precautions shall be taken to protect the structure. The Contractor shall notify the Engineer or Superintendent if excavation may cause the structure to undermine or collapse.

B.7 PIPE CULVERTS

Where specified on the drawings, the existing culvert shall be carefully removed, salvaged and either left at the site for the owner or reinstalled at a new grade or location. The value of any damage caused to the culvert due to the Contractor's negligence in salvage operation will be determined and deducted from the contract price.

All pipe culverts shall be installed in accordance with the standard detail drawings as noted on the drawings. If couplers are required, 5 corrugation couplers shall be used for up to and including 1200mm dia. pipe and 10 corrugation couplers for greater than 1200mm dia.

B.8 MOVING DRAINS OFF ROADS

Where an open drain is being removed from a road allowance, it must be reconstructed wholly on the adjacent lands with a minimum distance of 2.0 meters between the property line and the top of the bank, unless otherwise noted on the drawings. The excavated material shall be used to fill the existing open ditch and any excess excavated material shall be placed and levelled on the adjacent lands beyond the buffer strip, unless otherwise noted. Any work done on the road allowance, with respect to excavation, disposal of materials, installation of culverts, cleaning under bridges, etc., shall be to the satisfaction of the Road Authority and the Engineer.

B.9 TRIBUTARY OUTLETS

The Contractor shall guard against damaging the outlets of tributary drains. Prior to commencement of excavation on each property the Contractor shall contact the owner and request that all known outlet pipes be marked by the owner. All outlets so marked or visible or as noted on the profile, and subsequently damaged by the Contractor's operations will be repaired by the Contractor at his cost. All outlet pipes repaired by the Contractor under direction of the Drainage Superintendent or Engineer which were not part of the Contract shall be considered an extra to the contract price.

B.10 SEDIMENT BASINS AND TRAPS

The Contractor shall excavate sediment basins prior to commencement of upstream work as shown on the plan and profile. The dimension of the basin will be in a parabolic shape with a depth of 450mm below the proposed ditch bottom and the basin will extend along the drain for a minimum length of 15 meters.

A sediment trap 300mm deep and 5 meters long with silt fence placed across ditch bottom on the downstream end of the trap shall be constructed prior to and maintained during construction, to prevent silt from flushing downstream. The silt fence shall be removed and disposed of after construction.

B.11 SEEDING

.1 **Delivery:** The materials shall be delivered to the site in the original unopened containers which shall bear the vendor's guarantee of analysis and seed will have a tag showing the year of harvest.

.2 **Hydro Seeding:** Areas specified on drawings shall be hydro seeded and mulched upon completion of construction in accordance with O.P.S.S. 572 and with the following application rates:

Primary Seed (85 kg/ha.):	50% Creeping Red Fescue 40% Perennial Ryegrass 5% White Clover
Nurse Crop	Italian (Annual) Ryegrass at 25% of Total Weight
Fertilizer (300 kg/ha.)	8-32-16
Hydraulic Mulch (2000 kg/ha.)	Type "B"
Water (52,700 litres/ha.)	

Seeding shall not be completed after September 30.

.3 **Hand Seeding:** Hand seeding shall be completed daily with the seed mixture and fertilizer and application rate shown under "Hydro Seeding" above. Placement of the seed shall be by means of an approved mechanical spreader. Seeding shall not be completed after September 30.

SECTION C - TILE DRAIN

INDEX

<u>SECTION NUMBER</u>		<u>PAGE NUMBER</u>
C.1	PIPE MATERIALS.....	12
C.2	TESTING.....	12
C.3	LINE.....	12
C.4	CLEARING AND GRUBBING.....	13
C.5	PROFILE.....	13
C.6	GRADE.....	13
C.7	EXCAVATION.....	14
C.8	INSTALLATION.....	14
C.9	ROAD AND LANEWAY SUB-SURFACE CROSSINGS.....	15
C.10	BACKFILLING.....	15
C.11	UNSTABLE SOIL.....	15
C.12	ROCKS.....	15
C.13	BROKEN, DAMAGED OR EXCESS TILE.....	15
C.14	TRIBUTARY DRAINS.....	15
C.15	OUTLET PIPES.....	16
C.16	CATCHBASINS AND JUNCTION BOXES.....	16
C.17	BLIND INLETS.....	17
C.18	GRASSED WATERWAY.....	17
C.19	BACKFILLING EXISTING DITCHES.....	17
C.20	RECOMMENDED PRACTICE FOR CONSTRUCTION OF SUBSURFACE DRAINAGE SYSTEM.....	17

SECTION C

TILE DRAIN

C.1 PIPE MATERIALS

- .1 **Concrete Tile:** All tile installed under these specifications shall be sound and of first quality and shall meet all A.S.T.M. Specifications current at the time of tendering. Concrete tile shall conform to Designation C412 "Extra Quality" except that the minimum compression strengths shall be increased by 25%. Heavy Duty tile shall conform to Designation C412 "Heavy Duty Extra Quality".
- .2 **Corrugated Steel Pipe:** Unless otherwise specified all metal pipe shall be corrugated, rivetted steel pipe or helical corrugated steel pipe with a minimum wall thickness of 1.6mm (16 gauge) and shall be fully galvanized.
- .3 **Plastic Tubing:** The plans will specify the type of tubing or pipe, such as non-perforated or perforated (with or without filter material).
 - i) Corrugated Plastic Drainage Tubing shall conform to the current O.F.D.A. Standards
 - ii) Heavy Duty Corrugated Plastic Pipe shall be "Boss 1000" manufactured by the Big 'O' Drain Tile Co. Ltd. or approved equal
- .4 **Concrete Sewer Pipe:** The Designations for concrete sewer pipe shall be C14 for concrete sewer pipe 450mm (18") diameter or less; and C76 for concrete sewer pipe greater than 450mm (18") diameter. Where closed joints are specified, joints shall conform to the A.S.T.M. Specification C443.

Where concrete sewer pipe "seconds" are permitted the pipe should exhibit no damages or cracks on the barrel section and shall be capable of satisfying the crushing strength requirements for No. 1, Pipe Specifications (C14 or C76). The pipe may contain cracks or chips in the bell or spigot which could be serious enough to prevent the use of rubber gaskets but which are not so severe that the joint could not be mortared conventionally.
- .5 **Plastic Sewer Pipe:** The plans will specify the type of sewer pipe, such as non-perforated or perforated (with or without filter material). All plastic sewer pipe and fittings shall be "Boss Poly-Tite", ULTRA-RIB", "Challenger 3000" or approved equal with a minimum stiffness of 320 kpa at 5% deflection..
- .6 **Plastic Fittings:** All plastic fittings shall be "Boss 2000" or "Challenger 2000" with split coupler joints or approved equal.

C.2 TESTING

The manufacturer shall provide specimens for testing if required. The random selection and testing procedures would follow the appropriate A.S.T.M. requirements for the material being supplied. The only variation is the number of tile tested: 200mm to 525mm dia. - 5 tile tested, 600mm to 900mm dia. - 3 tile tested. The drain will be responsible for all testing costs for successful test results. Where specimens fail to meet the minimum test requirements, the manufacturer will be responsible for the costs of the unsuccessful tests. Alternately, the Engineer may accept materials on the basis of visual inspections and the receipt in writing from the Manufacturer of the results of daily production testing carried out by the Manufacturer for the types and sizes of the material being supplied.

C.3 LINE

Prior to stringing the tile, the Contractor shall contact the Superintendent or the Engineer in order to establish the course of the drain.

Where an existing drain is to be removed and replaced in the same trench by the new drain or where the new drain is to be installed parallel to an existing drain, the Contractor shall excavate test holes to locate the existing drain (including repairing drainage tile) at intervals along the course of the drain as directed by the Engineer and/or the Superintendent. The costs for this work shall be included in the tender price.

C.3 **LINE** (cont'd)

Where an existing drain is to be removed and replaced in the same trench by the new drain, all existing tiles shall be destroyed and all broken tile shall be disposed of off site.

The drain shall run in as straight a line as possible throughout its length, except that at intersections of other water courses or at sharp corners, it shall run on a curve of at least a 15 meter radius. The new tile drain shall be constructed at an offset from and generally parallel with any ditch or defined watercourse in order that fresh backfill in the trench will not be eroded by the flow of surface water. The Contractor shall exercise care not to disturb any existing tile drain or drains which parallel the course of the new drain, particularly where the new and the existing tile act together to provide the necessary capacity.

C.4 **CLEARING AND GRUBBING**

Prior to commencement of drain construction, all trees, scrub, fallen timber and debris shall be cleared and grubbed from the working area. Unless otherwise specified, the minimum width to be cleared and grubbed shall be 20 meters in all hardwood areas and 30 meters in all softwood areas (willow, poplar, etc.), the width being centred on the line of the drain.

All trees or limbs 150mm (6") or larger, that it is necessary to remove, shall be considered as logs and shall be cut and trimmed, and left in the working width separate from the brush, for use or disposal by the owner. Trees or limbs less than 150mm in diameter shall be cut in lengths not greater than 5 meters and placed in separate piles with stumps spaced not less than 75 meters apart in the working width, for the use or disposal of the owner. In all cases, these piles shall be placed clear of excavated materials, and not be piled against standing trees. No windrowing will be permitted. The clearing and grubbing and construction of the drain are to be carried out in two separate operations and not simultaneously at the same location.

C.5 **PROFILE**

The profile drawing shows the depth of cuts from the ground beside the stake to the final invert of the drain in meters and decimals of a meter. These cuts are established for the convenience of the Contractor; however, bench marks will govern the final elevation of the drain. Bench marks have been established along the course of the drain and their locations and elevations are noted on the profile drawing.

C.6 **GRADE**

The Contractor shall provide and maintain in good working condition, an approved system of establishing a grade sight line to ensure the completed works conform to the profile drawing. In order to confirm the condition of his system and to eliminate the possibility of minor errors on the drawings, he shall ensure his grade sight line has been confirmed to be correct between a minimum of two control points (bench marks) and shall spot check the actual cuts and compare with the plan cuts prior to commencement of tile installation. He shall continue this procedure from control point to control point as construction of the drain progresses. When installing a drain towards a fixed point such as a bore pipe, the Contractor shall uncover the pipe and confirm the elevation, using the sight line, a sufficient distance away from the pipe in order to allow for any necessary minor grade adjustments to be made in order to conform to the as built elevation of the bore pipe. All tile improperly installed due to the Contractor not following these procedures shall be removed and replaced entirely at the Contractor's cost.

When following the procedures and a significant variation is found, the Contractor shall immediately cease operations and advise the Engineer.

C.7 EXCAVATION

- .1 **Trench:** Unless otherwise specified, all trenching shall be done with a recognized farm tiling machine approved by the Engineer or Superintendent. The machine shall shape the bottom of the trench to conform to the outside diameter of the pipe for a minimum width of one-half of the outside diameter. The minimum trench width shall be equal to the outside diameter of the tile to be installed plus 100mm (4") on each side unless otherwise approved. The maximum trench width shall be equal to the outside diameter of the tile to be installed plus 250mm (10") on each side unless otherwise approved.
- .2 **Scalping:** Where the depths of cuts in isolated areas along the course of the drain as shown on the profile exceed the capacity of the Contractor's tiling machine, he shall lower the surface grade in order that the tiling machine may trench to the correct depth. Topsoil is to be stripped over a sufficient width that no subsoil will be deposited on top of topsoil. Subsoil will then be removed to the required depth and piled separately. Upon completion of backfilling, the topsoil will then be replaced to an even depth over the disturbed area. The cost for this work shall be included in his tender price.
- .3 **Excavator:** Where the Contractor's tiling machine consistently does not have the capacity to dig to the depths required or to excavate the minimum trench width required, he shall indicate in the appropriate place provided on the tender form his proposed methods of excavation.
Where the use of an excavator is either specified on the drawings or approved as evidenced by the acceptance of his tender on which he has indicated the proposed use of a backhoe he shall conform to the following requirements:
 - a) the topsoil shall be stripped and replaced in accordance with Section .2 "Scalping".
 - b) all tile shall be installed on a bed of 19mm crushed stone with a minimum depth of 150mm which has been shaped to conform to the lower segment of the tile.
 - c) the Contractor shall allow for the cost of the preceding requirements (including the supply of the crushed stone) in his lump sum tender price unless it is otherwise provided for in the contract documents.
- .4 **Backfilling Ditch:** Where the contract includes for a closed drain to replace an open drain and the ditch is to be backfilled, the Contractor shall install the tile and backfill the trench prior to backfilling the ditch unless otherwise noted. The distance the trench shall be located away from the ditch shall be as noted on the drawings, (beyond area required for stockpiling topsoil and backfilling). After tile installation is complete topsoil (if present) shall be stripped and stockpiled within the above limits prior to backfilling of ditch. Only tracked equipment shall be permitted to cross backfilled tile trench and must be at 90 degrees to line of tile.

C.8 INSTALLATION

The tile is to be laid with close fitting joints and in regular grade and alignment in accordance with the plan and profile drawings. The tiles are to be bevelled, if necessary, to ensure close joints (in particular around curves). Where, in heavy clay soils, the width of a joint exceeds 10mm the joint shall be wrapped with filter cloth as below. Where the width of a joint exceeds 12mm the tile shall first be removed and the joint bevelled to reduce the gap. The maximum deflection of one tile joint shall be 15 degrees. Where a drain connects to standard or ditch inlet catchbasins or junction box structures, the Contractor shall include in his tender price for the supply and installation of compacted Granular 'A' bedding under areas backfilled from the underside of the pipe to undisturbed soil. The connections will then be grouted.

Where a tile drain passes through a bore pit, the Tile Contractor shall include in his tender price for the supply and placement of compacted Granular "A" bedding from the underside of the pipe down to undisturbed soil within the limits of the bore pit.

As above and where soil conditions warrant, the Engineer may require (or as specified on the drawings) that each tile joint be wrapped with synthetic filter cloth. The width of the filter cloth shall be 300mm wide for tile sizes of 150mm to 300mm and 400mm wide for sizes of 350mm to 750mm. The filter cloth shall cover the full perimeter of the tile and overlap a minimum of 100mm or as specified on the drawings. The type of cloth shall be Mirafi 140NL for loam soils and 150N for sandy soil. Any such work not shown on the drawings shall be considered as an addition to the contract price unless specified on the drawings.

C.9 ROAD AND LANEWAY SUB-SURFACE CROSSINGS

All road and laneway crossings may be made with an open cut in accordance with standard detailed drawings in the specifications or on the drawings. The exact location of the crossing shall be verified and approved by the Road Authority and the Engineer and/or superintendent.

C.10 BACKFILLING

As the laying of the tile progresses, blinding up to the springline including compaction by tamping (by hand) is to be made on both sides of the tile. No tile shall be backfilled until inspected by the Engineer or Drainage Superintendent unless otherwise approved by the Engineer.

The remainder of the trench shall be backfilled with special care being taken in backfilling up to a height approximately 150mm above the top of the tile to ensure that no tile breakage occurs. During the backfilling operation no equipment shall be operated in a way that would transfer loads onto the tile trench. Surplus material is to be mounded over the tile trench so that when settlement takes place the natural surface of the ground will be restored. Upon completion, a minimum cover of 600mm is required over all tile. Where stones larger than 150mm are present in the backfill material, they shall be separated from the material and disposed of by the Contractor.

Where a drain crosses a lawn area, the backfilling shall be carried out as above except that, unless otherwise specified, the backfill material shall be mechanically compacted to eliminate settlement.

C.11 UNSTABLE SOIL

The Contractor shall immediately contact the Engineer or Superintendent if quicksand is encountered, such that installation with a tiling machine is not possible. The Engineer shall, after consultation with the Superintendent and Contractor, determine the action necessary and a price for additions or deletions shall be agreed upon prior to further drain installation. Where directed by the Engineer, test holes are to be dug to determine the extent of the affected area. Cost of test holes shall be considered an addition to the contract price.

C.12 ROCKS

The Contractor shall immediately contact the Engineer or Superintendent if boulders of sufficient size and number are encountered such that the Contractor cannot continue trenching with a tiling machine. The Engineer or Superintendent may direct the Contractor to use some other method of excavating to install the drain. The basis of payment for this work shall be determined by the Engineer and Drainage Superintendent.

If only scattered large stones or boulders are removed on any project, the Contractor shall haul same to a nearby bush or fenceline, or such other convenient location as approved by the Landowners(s).

C.13 BROKEN, DAMAGED TILE OR EXCESS TILE

The Contractor shall remove and dispose of off-site all broken (existing or new), damaged or excess tile or tiles. If the tile is supplied by the Municipality, the Contractor shall stockpile all excess tile in readily accessible locations for pickup by the Municipality upon the completion of the job.

C.14 TRIBUTARY DRAINS

Any tributary tile encountered in the course of the drain shall be carefully taken up by the Contractor and placed clear of the excavated earth. If the tributary tile drains encountered are clean or reasonably clean, they shall be connected into the new drain. Where existing drains are full of sediment, or contain pollutants, the decision to connect those drains to the new drain shall be left to the Engineer or Superintendent. Each tributary tile connection made by the Contractor shall be located and marked with a stake and no backfilling shall take place until the connection has been approved by the Engineer or Superintendent.

C.14 TRIBUTARY DRAINS (cont'd)

For tributary drains 150mm dia. or smaller connected to new tiles 250mm dia. or larger, and for 200mm dia. connected to 350mm dia. or larger, the Contractor shall neatly cut a hole in the middle of a tile length. The connections shall be made using a pre-fabricated adaptor. All other connections shall be made with pre-fabricated wyes or tees conforming to Boss 2000 split coupler or approved equal.

Where an open drain is being replaced by a new tile drain, existing tile outlets entering the ditch from the side opposite the new drain shall be extended to the new drain. All existing metal outlet pipes shall be carefully removed, salvaged, and left for the owner. Where the grade of the connection passes through the newly placed backfill in the ditch, the backfill material below the connection shall be thoroughly compacted and metal pipe of a size compatible with the tile outlet shall be installed so that a minimum length of 2 meters at each end is extending into undisturbed soil.

Where locations of tiles are shown on the drawings the Contractor shall include in his tender price, all costs for connecting those tiles to the new drain regardless of length.

Where tiles not shown on the drawings are encountered in the course of the drain, and are to be connected to the new drain, the Contractor shall be paid for each connection at the rate outlined in the Form of Tender and Agreement.

C.15 OUTLET PIPES

Corrugated steel pipe shall be used to protect the tile at its outlet. It shall have a hinged metal grate with a maximum spacing between bars of 40mm. The corrugated steel pipe shall be bevelled at the end to generally conform to the slope of the ditch bank and shall be of sufficient size that the tile can be inserted into it to provide a solid connection. The connection will then be grouted immediately.

The installation of the outlet pipe and the required rip-rap protection shall conform to the standard detailed drawing as noted on the drawing.

C.16 CATCHBASINS AND JUNCTION BOXES

.1 **Catchbasins:** Unless otherwise noted or approved, catchbasins shall be in accordance with O.P.S.D. 705.010, 705.030. All catchbasins shall include two - 150mm riser sections for future adjustments. All ditch inlet catchbasins shall include one 150mm riser section for future adjustments. The catchbasin top shall be a "Bird Cage" type substantial steel grate, removable for cleaning and shall be inset into a recess provided around the top of the structure. The grate shall be fastened to the catchbasin with bolts into the concrete. Spacing of bars on grates for use on 600mmx600mm structures shall be 65mm centre to centre. Spacing of bars on grates for use on structures larger than 600mmx600mm shall be 90mm with a steel angle frame.

The exact location and elevation of catchbasins shall be approved by the Road Authority or the Engineer/Superintendent. Catchbasins offset from the drain shall have "Boss 2000" 200mm diameter leads or approved equal unless otherwise noted and the leads shall have a minimum of 600mm of cover. The leads shall be securely grouted at the structures and the drain.

.2 **Junction Boxes:** Junction boxes shall be the precast type unless otherwise approved. Dimensions for precast junction boxes shall conform to those for catchbasins. The inside dimensions of the box shall be a minimum of 100mm larger than the outside diameter of the largest pipe being connected. The minimum cover over the junction box shall be 600mm. Benching to spring line shall be supplied with all junction boxes.

.3 **Connections:** Catchbasins and junction boxes shall not be ordered until elevations of existing pipes being connected have been verified in the field as indicated on the drawings. All connections shall be securely grouted at both the inside and outside walls of the structure.

.4 **Installation:** Where the native material is clay, all catchbasins shall be backfilled with an approved granular material placed and compacted to a minimum width of 300mm on all sides with the following exception. Where the native material is sandy or granular in nature it may be used as backfill. Filter cloth shall be placed between the riser sections of all catchbasins.

C.16 CATCHBASINS AND JUNCTION BOXES (cont'd)

Where the Contractor has over excavated or where ground conditions warrant, the structure shall be installed on a compacted granular base.

The Contractor shall include in his tender price for the construction of a berm behind all ditch inlet structures. The berm shall be constructed of compacted clay keyed 300mm into undisturbed soil. Topsoil shall be distributed to a 65mm thickness and seeded unless otherwise specified. The Contractor shall also include for regrading, shaping and seeding of road ditches for a maximum of 15 meters each way from all catchbasins.

C.17 BLIND INLETS

Where specified, blind inlets shall be installed along the course of the drain. In accordance with details on the drawings.

C.18 GRASSED WATERWAY

Topsoil to be stripped from construction area and stockpiled prior to construction of waterway. Waterway to be graded into a parabolic shape to the width shown on the drawings. Topsoil to be relevelled over the waterway and other areas disturbed by construction.

Waterway to be prepared for seeding by harrowing and then seeded by drilling followed by rolling. Seeding rate to be 85 Kg/Ha with the following mixture:

- 30% Canon Canada Bluegrass
 - 25% Koket Chewings Fescue
 - 30% Rebel Tall Fescue
 - 15% Diplomat Perennial Rye
- Plus #125 Birdsfoot Trefoil (25% of Total Weight)

C.19 BACKFILLING EXISTING DITCHES

The Contractor shall backfill the ditch sufficiently for traversing by farm machinery. If sufficient material is not available from the old spoil banks to fill in the existing ditch, the topsoil shall be stripped and the subsoil shall be bulldozed into the ditch and the topsoil shall then be spread over the backfilled ditch unless otherwise specified on the contract drawings. The Contractor shall ensure sufficient compaction of the backfill and if required, repair excess settlement up to the end of the warranty period. The final grade of the backfilled ditch shall provide an outlet for surface water.

C.20 RECOMMENDED PRACTICE FOR CONSTRUCTION OF SUBSURFACE DRAINAGE SYSTEM

Drainage guide for Ontario, Ministry of Agriculture, Food and Rural Affairs Publication Number 29 and its amendments, dealing with the construction of Subsurface Drainage systems, shall be the guide to all methods and materials to be used in the construction of tile drains except where superseded by other specifications of this contract.

The requirements of licensing of operators, etc. which apply to the installation of closed drains under the Tile Drainage Act shall also be applicable to this contract in full unless approval otherwise is given in advance by the Engineer.

SECTION D

SPECIFICATIONS FOR MUNICIPAL DRAINS CROSSING COUNTY ROADS

1. These specifications apply to Municipal Drains crossing County, Regional, or Highway Roads. Where the word "County" is used, it shall be deemed to apply to the appropriate owning authority.
2. These specifications supplement the conditions outlined in the Specifications for the Construction of Municipal Drainage works, but in no way limit the County's Specifications and Regulations governing the construction of drains on the County's Road Allowance.
3. The County will supply no labour, equipment or materials for the construction of the road crossing unless otherwise noted on the drawings.
4. Before proceeding with any work on County Road property, the Contractor shall ensure a road crossing permit has been obtained and he shall notify the County Engineer and the Drainage Engineer or Superintendent, a minimum of 48 hours in advance (exclusive of Saturdays, Sundays and Holidays). A site meeting shall be held with the affected parties to review in detail the crossing and/or its related works. The County Inspector and the Drainage Engineer will inspect the work while in progress to ensure that the work is done in strict accordance with the specifications.
5. The drawings will specify the type of crossing which is to be constructed i.e. by boring or by open cut.
6. Boring shall be carried out in accordance with the section of the Specifications for the Construction of Municipal Drainage Works entitled "General Conditions" sub-section A16 except that:
 - bore pits shall be kept back at least 1 meter from the edge of pavement and where bore pits are made in any portion of the shoulder, the excavated material shall be disposed of off the road allowance and the pit backfilled with thoroughly compacted Granular "A" for its entire depth.
 - bore pits and excavations outside of the shoulder area may be backfilled with native material compacted to a density of 95% Standard Proctor. All disturbed areas shall be neatly shaped, have the topsoil replaced and hand seeded.
7. Open Cut shall be carried out in accordance with the section of the Specifications for the Construction of Municipal Drainage Works entitled "General Conditions" sub-section A16 except that:
 - the excavated material removed from the travelled portion of the road and the full width of the shoulder shall be removed and disposed of off the road allowance
 - backfill material for the excavation on the travelled portion and shoulders shall be as follows:
 - a) from the bottom of the excavation to a level 300mm below the road grade - the material shall meet the requirements for M.T.O. Granular 'B'. The backfill shall be placed in lifts not exceeding 300mm in thickness and each lift shall be thoroughly compacted to produce a density of 100% Standard Proctor.
 - b) the top 300mm of backfill material shall meet the requirements for M.T.O. Granular 'A' and shall be placed in lifts not exceeding 150mm in thickness and each lift shall be thoroughly compacted to produce a density of 100% Standard Proctor.

7. (cont'd)
- c) where the road surface is paved, the Contractor shall be responsible for placing an HL-4 Hot Mix Asphalt patch of the same thickness as the existing pavement. The asphalt patch shall be flush with the existing roadway on each side and not overlap. If the asphalt patch is not placed immediately over the backfill, the Granular 'A' shall be brought up flush with the existing asphalt and a liberal amount of calcium chloride shall be spread on the gravel surface. The asphalt patch must be completed within 10 days of cutting the pavement.
 - d) the excavated material from the trench beyond a point 1.25 meters from the travelled portion or beyond the outside edge of the gravel shoulder, may be replaced in the trench in the case of covered drains. This material should be compacted in layers not exceeding 600mm.
8. All barricades, signing and flagging shall conform to the "Traffic Control Manual for Roadway Work Operations".
9. No construction material and/or equipment is to be left within 3 meters of the edge of pavement overnight or during periods of inclement weather.
10. No construction shall take place during inclement weather or periods of poor visibility.

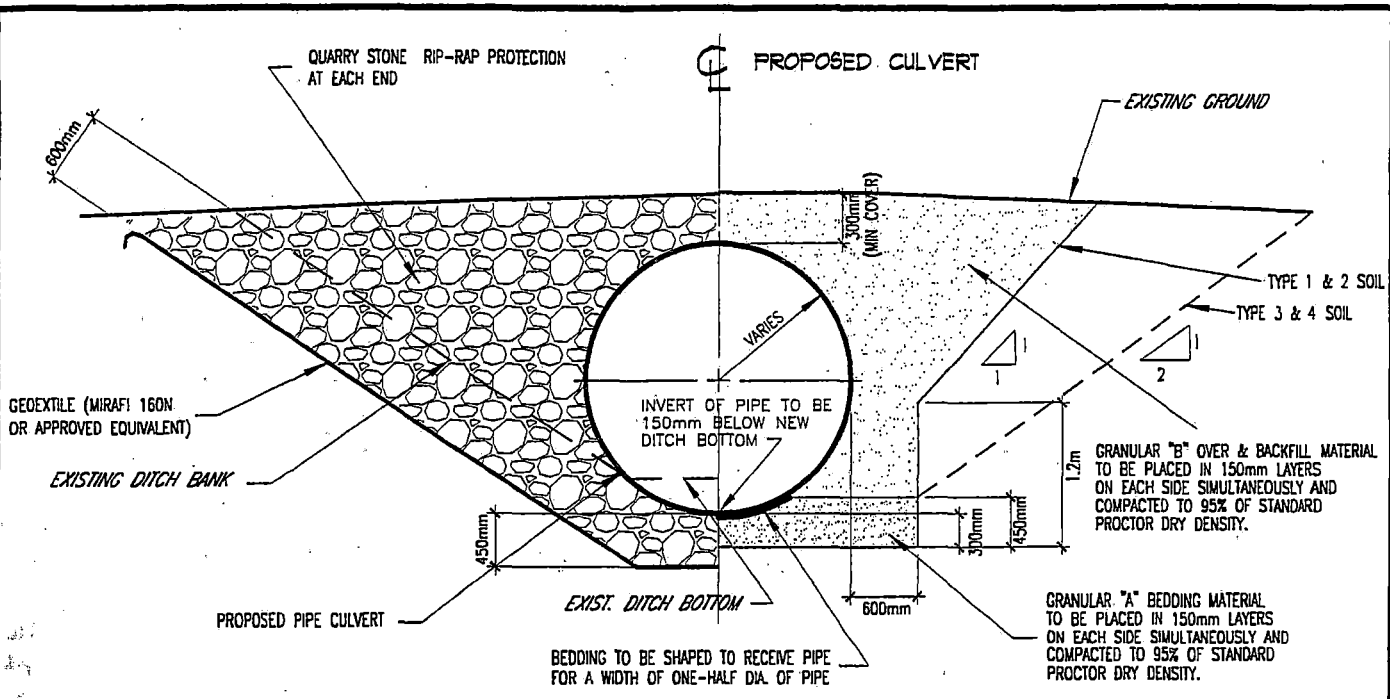

HALF ELEVATION

HALF SECTION

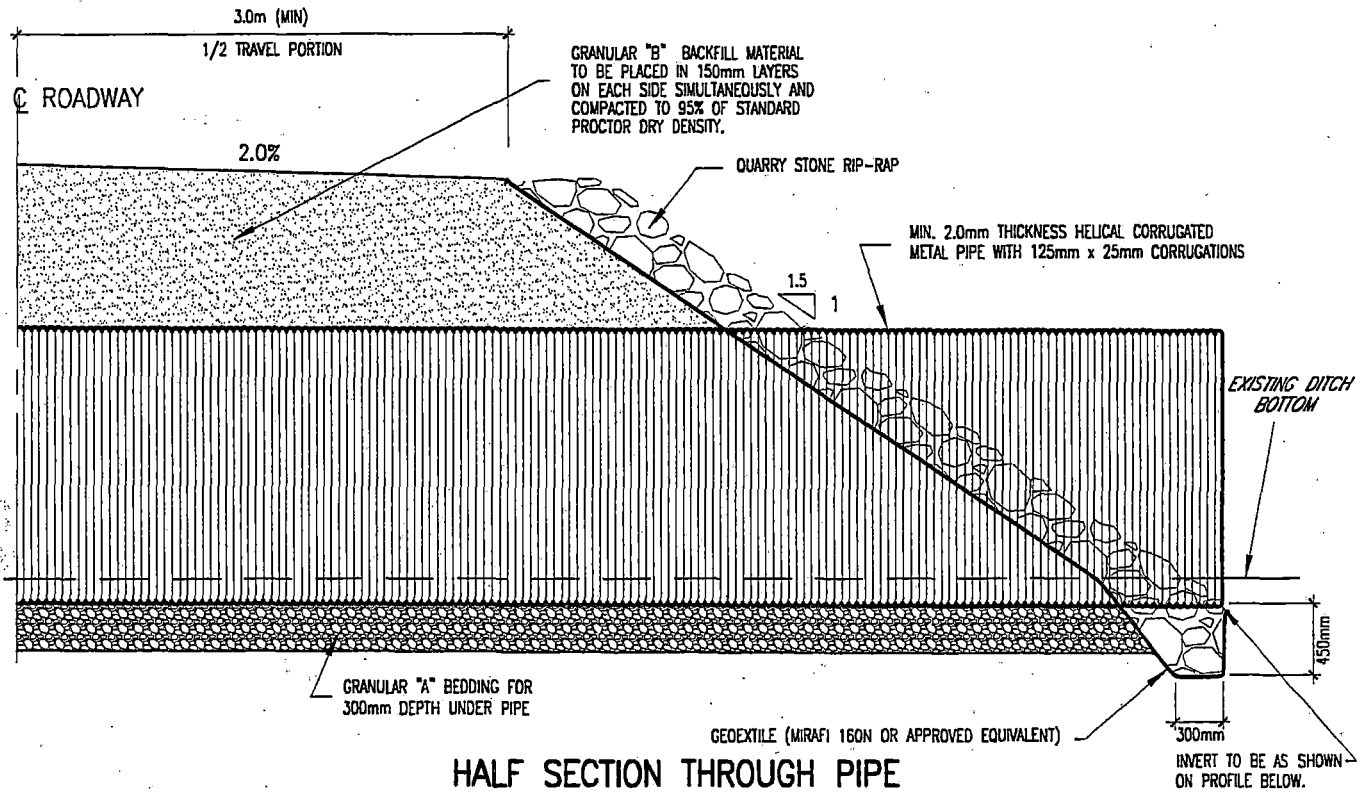

HALF SECTION THROUGH PIPE

NOTES

- 1) WHERE THE CULVERT IS TO BE INSTALLED IN POOR SOIL CONDITIONS, THE BEDDING MATERIAL SHALL BE 19mm CRUSHED STONE COMPLETELY WRAPPED IN GEOTEXTILE SUCH AS MIRAFI 160N OR APPROVED EQUIVALENT.

TYPICAL FARM CULVERT INSTALLATION DETAIL		
Scale: N.T.S.	Approved by: M.P.D.	Date: January 1983
Drawn by: jk		Revised: November 2000
ELEVATION & SECTION		STANDARD DETAILED DRAWING
 SPRIET ASSOCIATES LONDON LIMITED CONSULTING ENGINEERS ARCHITECTS		No. 01

1. TILE TO BE BUTT END TO SEWER PIPE AND WRAPPED WITH GEOTEXTILE
2. TILE INSERTED 150mm INTO C.S.P. AND TO BE JOINT GROUTED

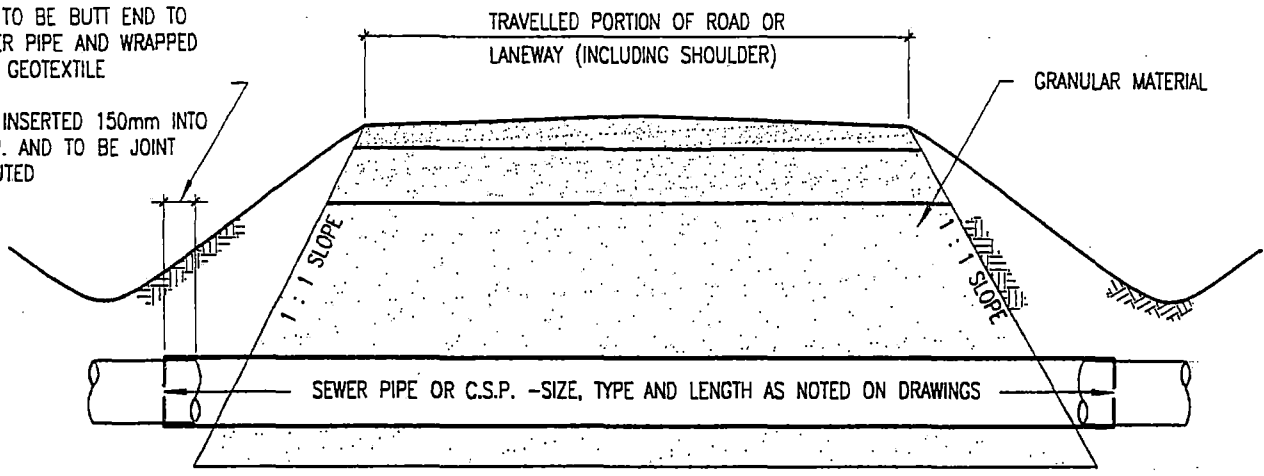

SECTION THROUGH PIPE

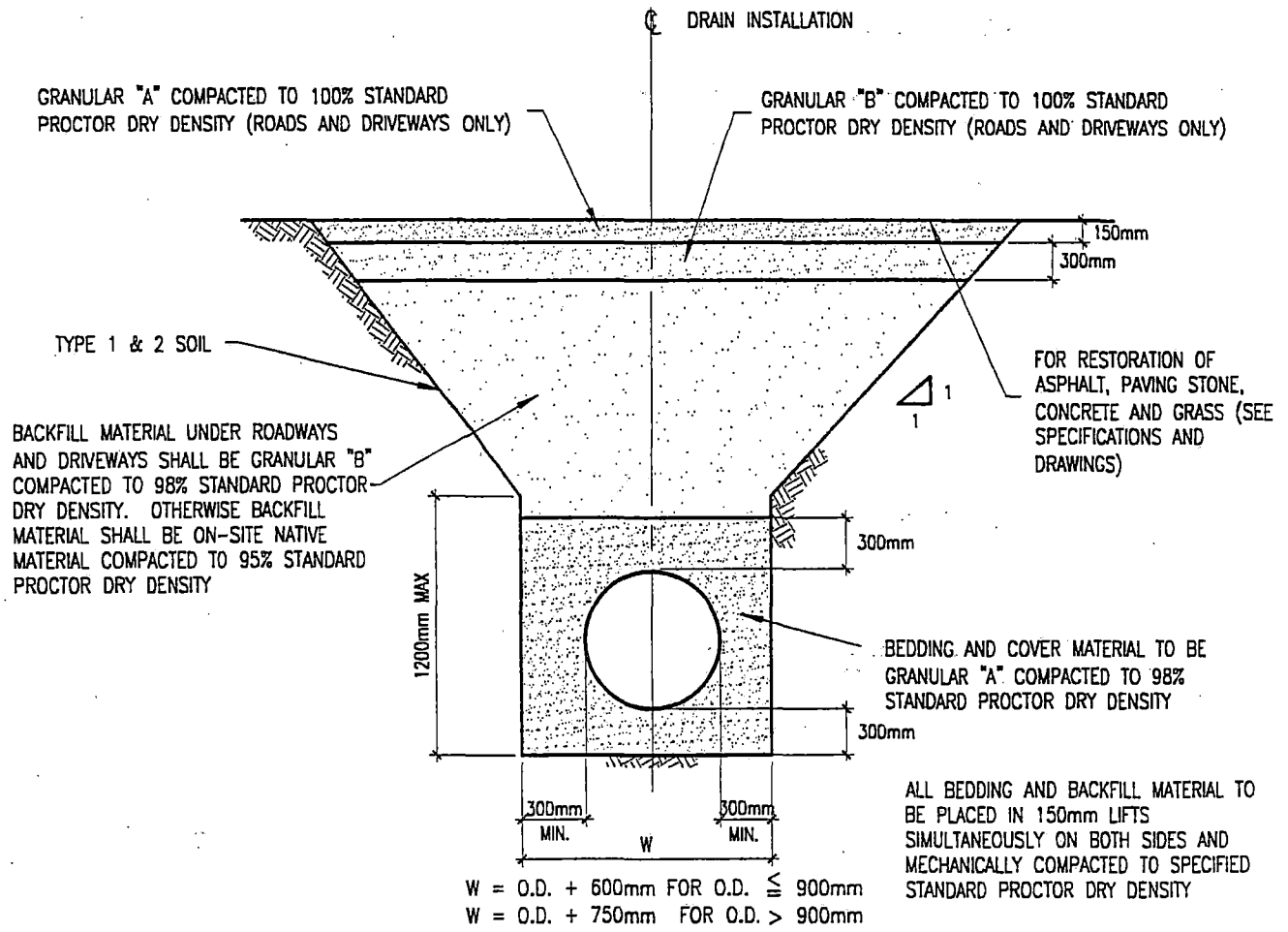

CROSS SECTION

TYPICAL INSTALLATION DETAIL FOR FLEXIBLE PIPE		
Scale: N.T.S.	Approved by: M.P.D.	Date: January 1983
Drawn by: jk		Revised: November 2000
ELEVATION & SECTION		STANDARD DETAILED DRAWING No. 02
 SPRIET ASSOCIATES LONDON LIMITED CONSULTING ENGINEERS ARCHITECTS		

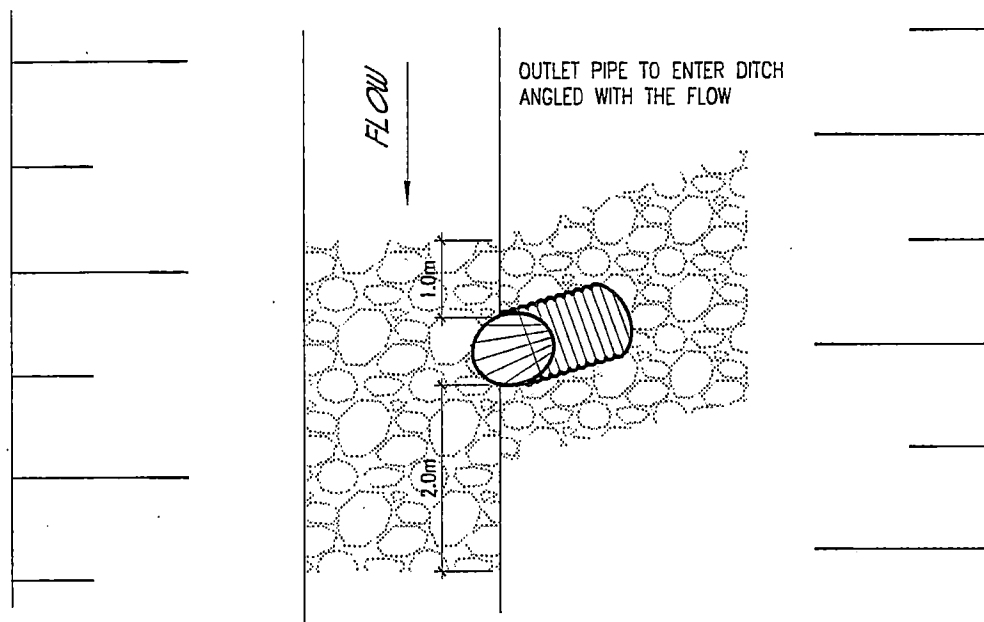

PLAN

NOTES

1. WHERE THE DISTURBED AREA EXCEEDS THE MIN. WIDTHS, RIP-RAP TO EXTEND TO A MIN. OF 600mm BEYOND THE DISTURBED AREA

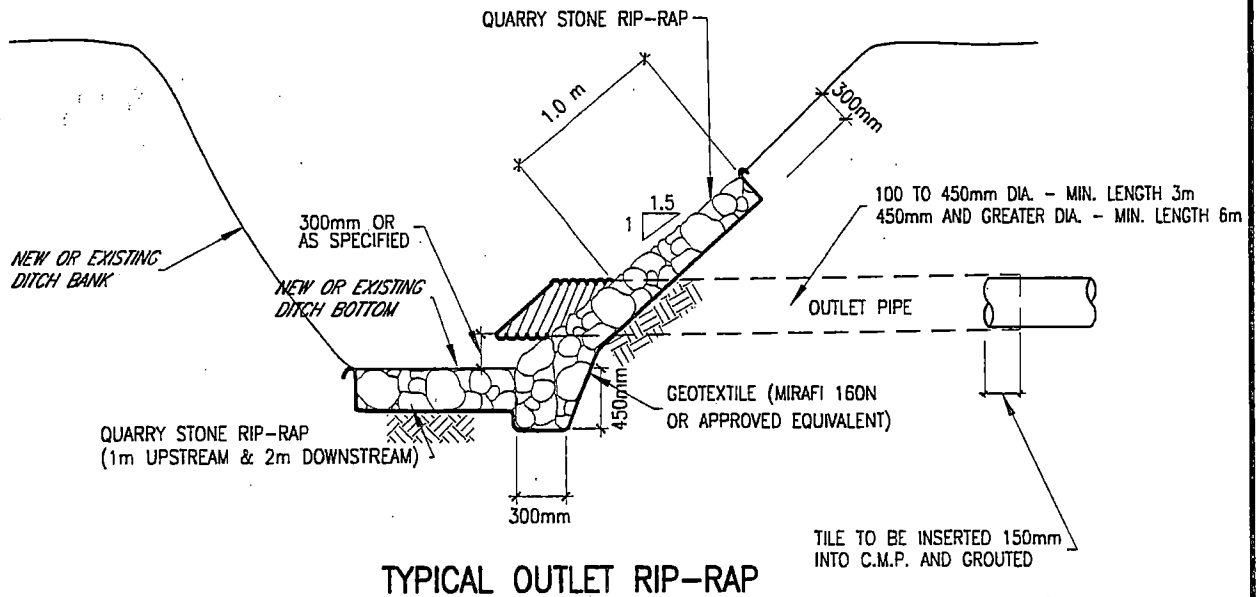

TYPICAL OUTLET RIP-RAP

NOTES

1. RIP-RAP TO EXTEND UP THE SLOPE TO 1 METER ABOVE TOP OF OUTLET
2. WHERE SURFACE RUN ENTERS DITCH AT OUTLET PIPE, A ROCK CHUTE SHALL BE INSTALLED (SEE S.D.D. No. 05) AND PIPE SHALL BE INSTALLED ADJACENT TO ROCK CHUTE.
3. HINGED RODENT GATE TO BE AFFIXED TO END OF OUTLET PIPE.

TYPICAL OUTLET RIP-RAP THROUGH SIDE SLOPE OF DITCH		
Scale: N.T.S.	Approved by:	Date: January 1983
Drawn by: jk	M.P.D.	Revised: November 2000
PLAN & SECTION		STANDARD DETAILED DRAWING
 SPRIET ASSOCIATES LONDON LIMITED CONSULTING ENGINEERS ARCHITECTS		No. 03

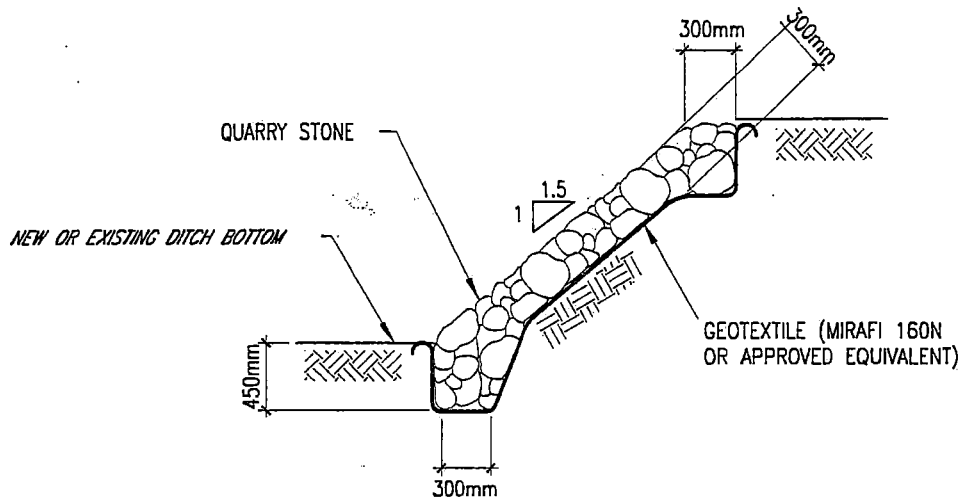

TYPICAL DITCH BANK RIP-RAP

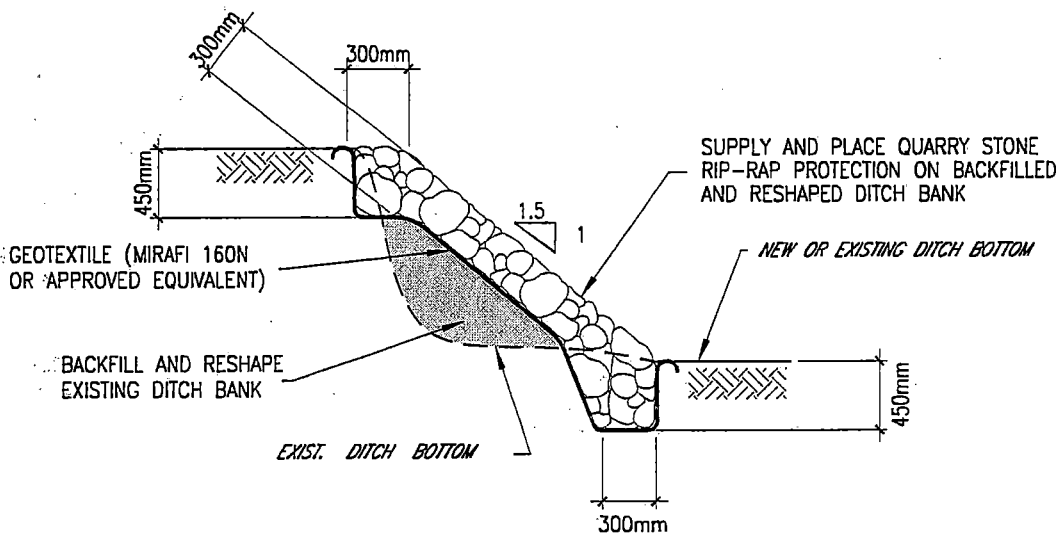

**TYPICAL DITCH BANK RIP-RAP
WITH BACKFILLING OF WASHOUT**

TYPICAL DITCH BANK RIP-RAP DETAILS		
Scale: N.T.S.	Approved by:	Date: July 2000
Drawn by: jk	M.P.D.	Revised: November 2000
SECTIONS		STANDARD DETAILED DRAWING No. 04
 SPRIET ASSOCIATES LONDON LIMITED CONSULTING ENGINEERS ARCHITECTS		

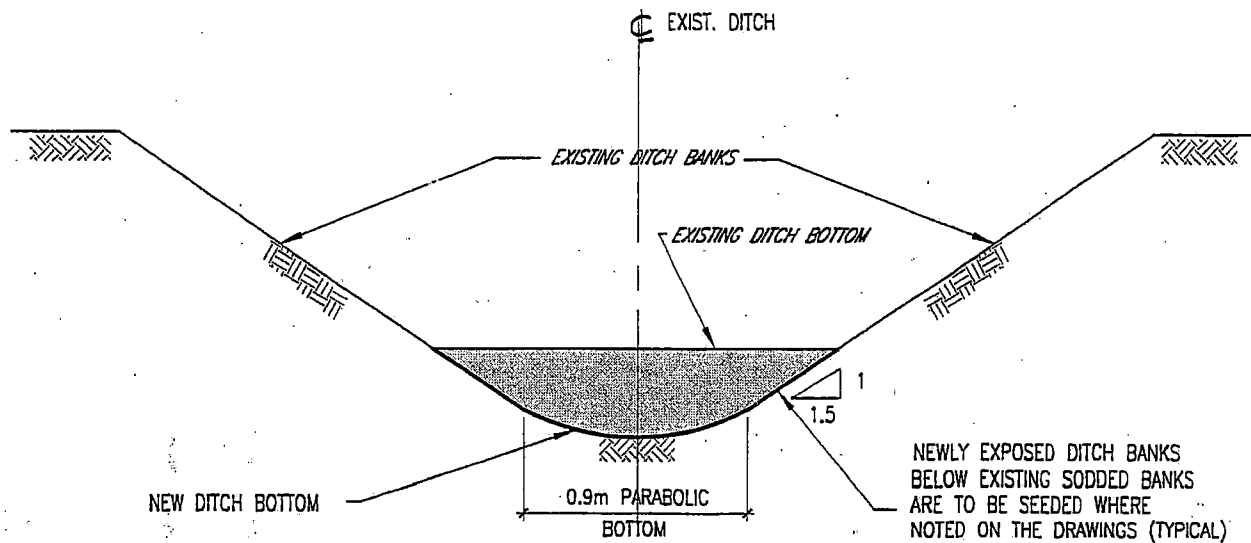

TYPICAL DITCH BOTTOM CLEANOUT

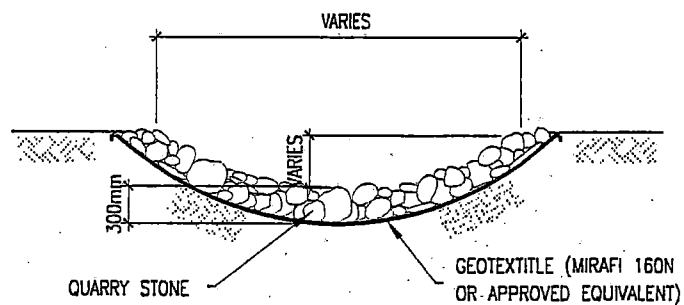
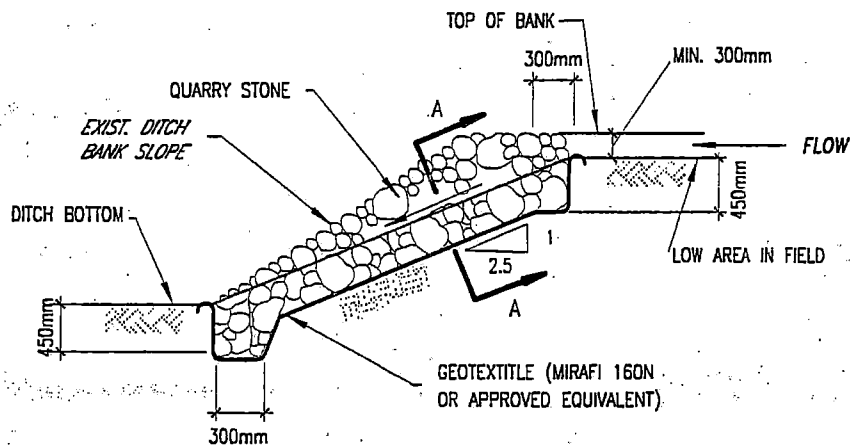

SECTION A-A

TYPICAL ROCK CHUTE

TYPICAL DITCH BOTTOM CLEANOUT TYPICAL ROCK CHUTE CONSTRUCTION		
Scale: N.T.S.	Approved by:	Date: November 2000
Drawn by: jk	M.P.D.	Revised:
SECTIONS		STANDARD DETAILED DRAWING No. 05
 SPRIET ASSOCIATES LONDON LIMITED CONSULTING ENGINEERS ARCHITECTS		